

Power chart / Leistungsschaubild
Graphique de puissance / Grafica de potencia

*This chart compares relative values obtained on a dynometer in relative conditions of temperature and pressure, so don't reflect absolute values.

— Original silencer
- - - Racing silencer
... e9-Approval silencer



www.ixil.com

Ref. **6088**

Adaptable silencer / Adaptable schalldämpfer / Silenciador adaptable / Silencieux adaptable

Mark: HONDA
Model: VTR 1000 F
Motorcycle Type: SC36
Exhaust Type: Original position

- * Not contractual document.
- * All silencers without e9-Approval number are for competition use only.
- * This company reserve the right to update or amend without prior notice.

GB FITTING INSTRUCTIONS

1. Remove the original silencer.
2. Mount the adaptable silencer as shown in the drawing.
3. Check that the fasteners are properly tightened.

D MONTAGEANLEITUNG

1. Bauen Sie den Original-Schalldämpfer ab.
2. Befestigen Sie den Umbau-Schalldämpfer, wie auf der Zeichnung adgebildet.
3. Überprüfen Sie, ob die Befestigungen richtig festgezogen sind.

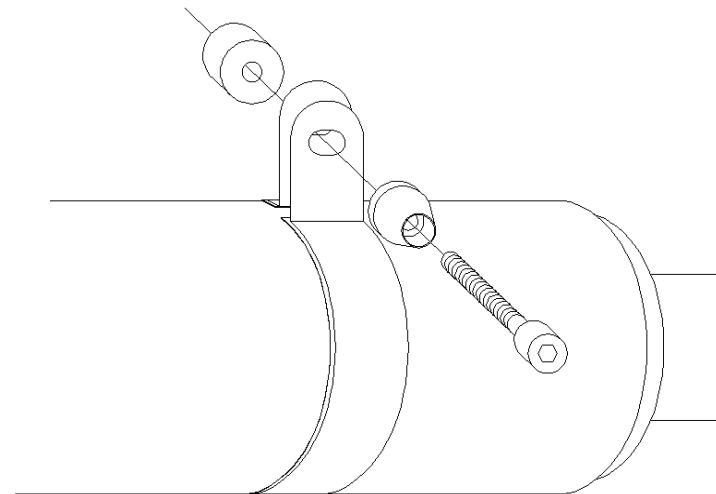

F INSTRUCTIONS DE MONTAGE

1. Démonter le silencieux d'origine.
2. Monter le silencieux adaptable comme indiqué sur le schéma.
3. Vérifier si le fixations sont bien serrées.

E INSTRUCCIONES DE MONTAJE

1. Desmontar el silenciador original.
2. Montar el silenciador adaptable como muestra la figura.
3. Comprobar que las fijaciones estén debidamente apretadas.

