



YOSHIMURA

RESEARCH&DEVELOPMENT OF AMERICA, INC.

5420 DANIELS STREET STE A, CHINO CA 91710 · (800) 634-9166 · (909) 628-4722 · FAX (909) 591-2198

www.yoshimura-rd.com

RACE SERIES

Qualified Manufacturer Declared "Modified Part"

2017 ~ 2018

Honda CRF250L/Rally
123402D520 (SS/CF)

RS-4 Stainless Steel Slip-On

FOR CLOSED COURSE COMPETITION ONLY; NOT INTENDED FOR STREET USE

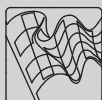

Race Series systems are:

- NOT CARB/EPA tail-pipe emissions compliant.
- NOT street legal.
- For "Closed Course Competition" use only.

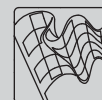

You must know how to remove and replace your stock exhaust in order to install this product otherwise have it installed by a professional mechanic. Keep all stock parts from your existing system as some components may be necessary to install your new Yoshimura exhaust depending on the application. Read through all instructions before beginning installation. Exhaust system can be extremely hot. Let motorcycle cool down before beginning installation. Always wear hand and eye protection and take precautionary measures to avoid injury.



NOTE: IN THE STATE OF CALIFORNIA, IT IS ILLEGAL TO MODIFY THE EMISSION CONTROL SYSTEM, WHICH INCLUDES THE CARBURETORS OF ANY VEHICLE.

Assembly Diagram

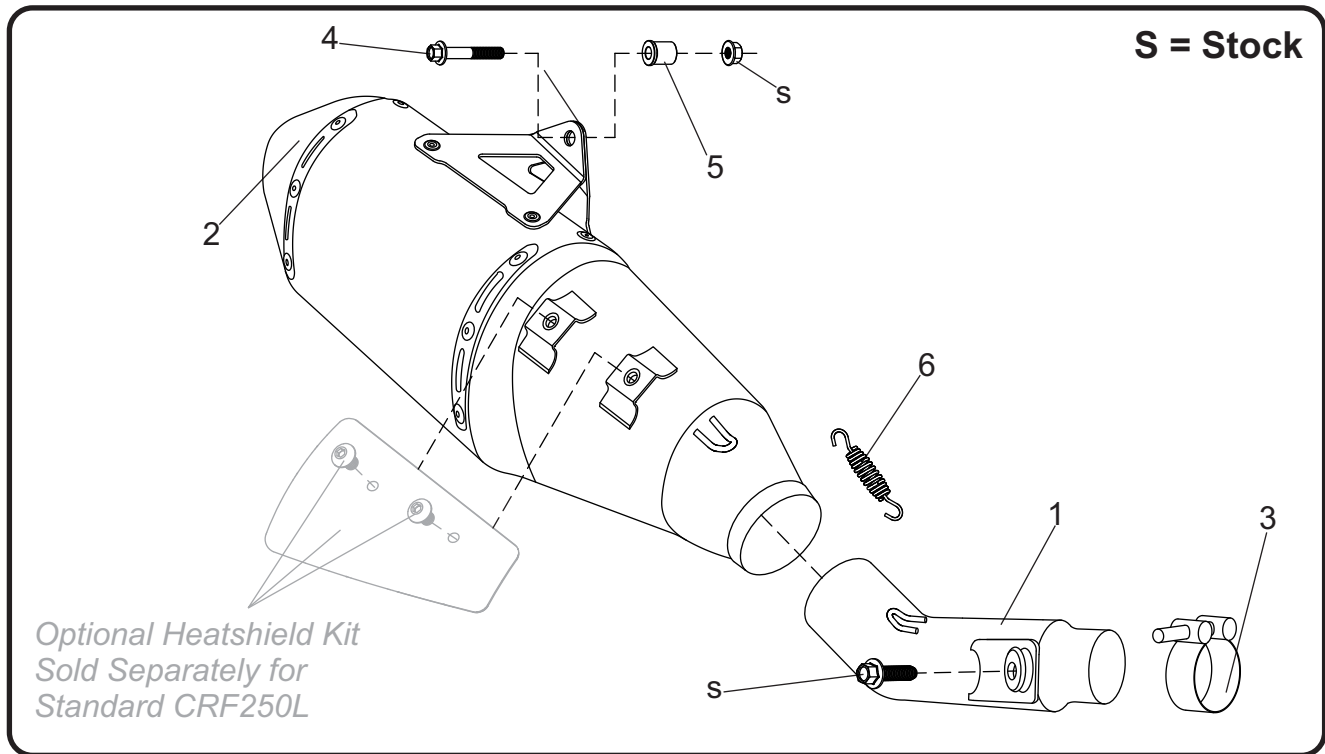

No.	Item	Description	Qty.
1	12340-435	Yoshimura Tailpipe	1
2	123402D520-RMA	Yoshimura Muffler Assembly	1
3	22055	Exhaust Clamp	1
4	M8X60H	8mm x 60mm Flanged Hex Head Bolt	1
5	ALS-058	Aluminum Spacer	1
6	RACE-SPX-1	Short Exhaust Spring	1
**	ST-200	Spring Puller Tool	1
**	17029	Sticker Kit Sheet	1

** Not shown in diagram.

CAUTION: Exhaust system can be extremely hot. Let motorcycle cool down before beginning installation. Always wear hand and eye protection and take precautionary measures to avoid injury.

WARNING: Always properly support vehicle with a stand and/or lift when servicing or performing any work. Unstable vehicles may present dangerous conditions and may cause property damage and/or personal injury.

NOTE: Read through all instructions before beginning installation.

Removal

1. For CRF250L Rally, follow steps "a".
For standard CRF250L, follow steps "b".
 - 1a. Remove right rear side panel.
 - 1b. Remove muffler cover.
2. Loosen muffler exhaust clamp.
3. Remove muffler chassis mount bolt.
4. While securely supporting the stock muffler assembly, remove muffler mount bolt and carefully remove the stock muffler assembly.

Installation

1. Slide (No. 3) 22055, exhaust clamp over (No. 1) 12340-435, tailpipe inlet. Do not torque at this time.
2. Install (No. 1) 12340-435, tailpipe inlet over stock header outlet. Align chassis mount and secure using the stock chassis mount bolt. Do not torque at this time.
3. Install (No. 2) 123402D520-RMA, muffler onto tailpipe outlet. Align muffler mount bracket to the frontside of muffler mount and secure using (No. 4) M8X60H, 8mm bolt, (No. 5) ALS-058, aluminum spacer, and stock nut as shown on the assembly diagram. Torque muffler mount bolt to factory specification.
4. Torque chassis mount bolt to factory specification.

5. Torque (No. 3) 22055, exhaust clamp to 8.5 Nm (0.86 kg-m, 6 ft-lb).
6. Install (No. 6) RACE-SPX-1, short exhaust spring between muffler and tailpipe.

- 7a. Re-install right rear side panel.
- 7b. Install optional heatshield kit **990BG123400**.

Note: Heatshield kit is sold separately for standard CRF250L.

8. Before starting vehicle, check for proper clearance between new exhaust system and rear suspension (i.e. tire, swingarm, brakes, rear shock, and etc.) If any problem is found, please carefully follow through the installation steps again. If problem still persists, please call Yoshimura Tech Department at (800) 634-9166 / in CA (909) 628-4722.
9. It is recommended that the muffler and tailpipe be wiped down with rubbing alcohol to remove oil and fingerprints. This will help prevent tarnishing of the finish after the exhaust is heated up.

Note: After starting vehicle, it is normal for new exhaust system and muffler to emit smoke until oil residue burns off.