

Rear CNC Caliper P2 30 Code XA1J040



Spare Parts • Ricambi

Spindle / Perno

XA1J009

Pin / Copiglia

05454217

Spring / Molletta

XA1J046

Bleeding screw / Vite spurgo

101739

Technical Characteristics • Caratteristiche Tecniche

Pistons / Pistoni Ø	30 mm.
Construction Material / Materiale	CNC Aluminium / Alluminio CNC
Finishing / Finissaggio	Hard anodizing / Anodizzazione dura
Weight (with pads) / Massa (con pastiglie)	348 gr.
Brake Fluid / Fluido freni	DOT 4
Hardware / Viteria	Titanium / Titanio
Pistons / Pistoni	Titanium / Titanio
Center to center / Interasse	64 mm.
Offset / Offset	16,5 mm.

To be used with 24 mm. rotor brake disc height.
Pastiglia da utilizzare con fascia frenante h = 24 mm.

To be used with 30 mm. rotor brake disc height.
Pastiglia da utilizzare con fascia frenante h = 30 mm.

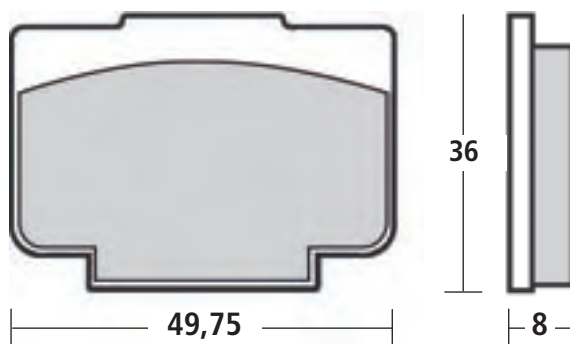
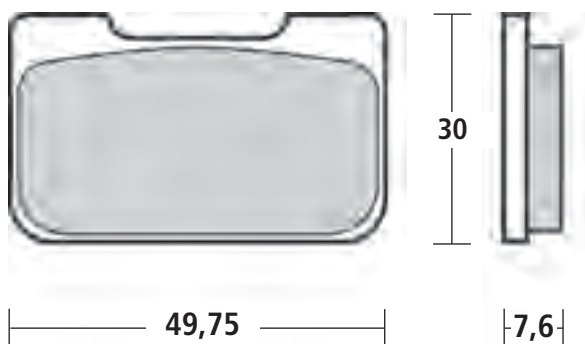

Pads • Pastiglie

Code	Performance	Life
07934020	•	•
X988831	+	•
Sintered		
X988822	++	•
Sintered		

Pads • Pastiglie

Code	Performance	Life
07934010	•	•
X988802	++	•
Sintered		