

## Rear CNC Caliper P2 34 Code X988870

### Spare Parts • Ricambi

Spindle / Perno

X988815

Spring / Molletta

X988818

Bleeding screw / Vite spurgo

X101739



### Technical Characteristics • Caratteristiche Tecniche

Pistons / Pistoni Ø	34 mm.
Construction Material / Materiale	CNC Aluminium / Alluminio CNC
Finishing / Finissaggio	Hard anodizing / Anodizzazione dura
Weight (with pads) / Massa (con pastiglie)	394 gr.
Brake Fluid / Fluido freni	DOT 4
Hardware / Viteria	Titanium / Titanio
Pistons / Pistoni	Titanium / Titanio
Center to center / Interasse	64 mm.
Offset / Offset	16,5 mm.

To be used with 24 mm. rotor brake disc height.  
Pastiglia da utilizzare con fascia frenante h = 24 mm.

To be used with 30 mm. rotor brake disc height.  
Pastiglia da utilizzare con fascia frenante h = 30 mm.

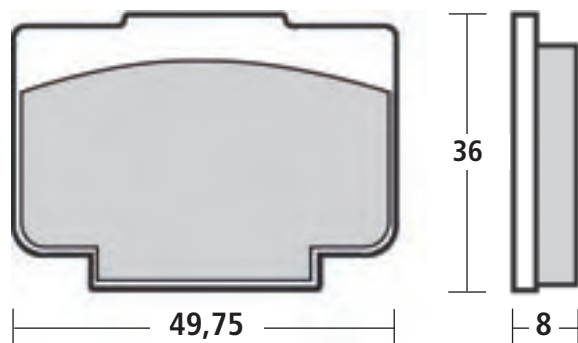
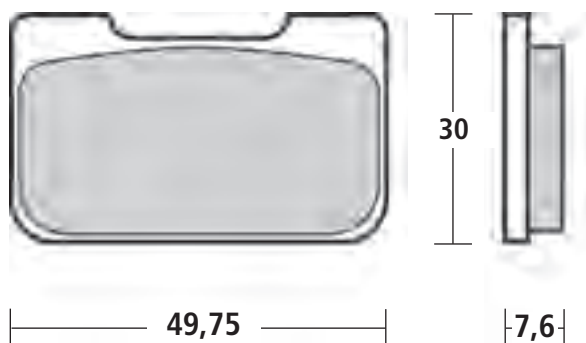

### Pads • Pastiglie

Code	Performance	Life
07934020	•	•
X988831	+	•
Sintered		
X988822	++	•
Sintered		

### Pads • Pastiglie

Code	Performance	Life
07934010	•	•
X988802	++	•
Sintered		