

HYPERPRO

LOWERING KIT / VERLAGINGSSET for YAMAHA YZF 600 R6 Models '03-'05

LK-YA06-002-40 PART LIST

LINK0010 - Lowering link/ verlagingslink	2
SL144710 - Stroke limiter / slagbeperker	1
M10 Washer/ ring	6
-	-

ALL IDEAS, DESIGNS, ARRANGEMENTS AND PLANS INDICATED OR REPRESENTED BY THIS DRAWING ARE OWNED BY HYPERPRO AND WERE CREATED, EVOLVED AND DEVELOPED FOR USE ON AND IN CONNECTION WITH THE SPECIFIC PROJECT. NONE SUCH IDEAS, DESIGNS, ARRANGEMENTS OR PLANS SHALL BE USED BY OR DISCLOSED TO ANY PERSON, FIRM OR CORPORATION FOR ANY PURPOSE WHATSOEVER WITHOUT THE WRITTEN PERMISSION OF HYPERPRO.

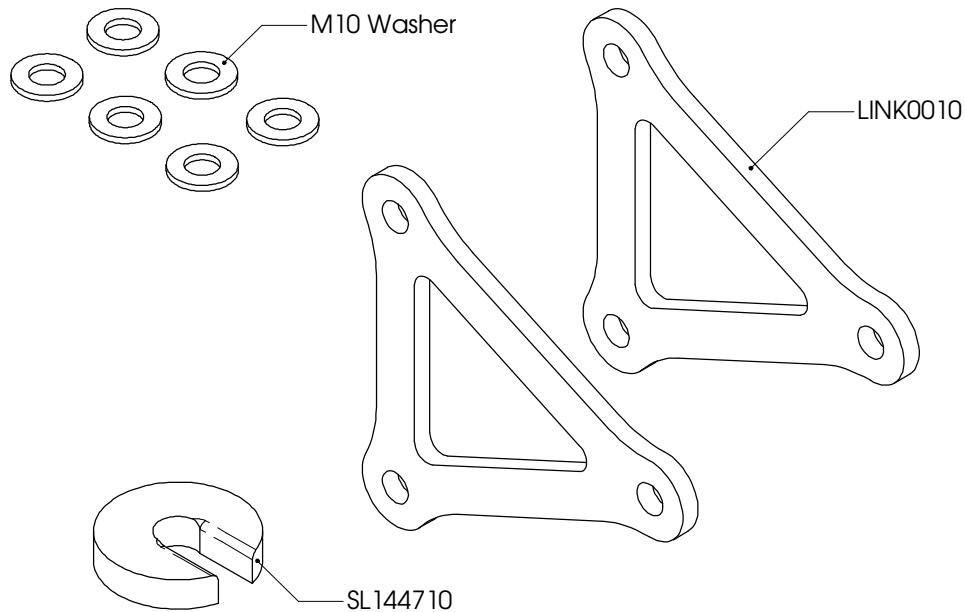

Inbouw handleiding

VOORZIJD

De vorkpoten maximaal 15mm door de bovenste kroonplaat heen steken. De veer-voorspanning minimaal zetten (tegen de klok in draaien). De luchtkamer reduceren als de vork wil doorslaan.

ACHTERZIJD

De bestaande links vervangen door de HYPERPRO verlagingslinks. Let er hierbij op dat de pijl in de rijrichting wijst. De slagbeperker onder het aanslagrubber van de achterschokbreker plaatsen. Het achterwiel eerst belasten voordat de link vastgezet wordt.

LET OP! DE LENGTE VAN DE ZIJSTANDAARD MOET 20-25mm INGEKORT WORDEN.

Instruction manual

FRONT

Mount the fork legs max 15mm through the triple clamp. Turn the preload adjuster to minimum preload (counter clockwise). Reduce the air chamber if the fork hits the end of its stroke.

REAR

Replace the original link by the HYPERPRO lowering link. Make sure that the arrow is pointing in the riding direction. Put the stroke limiter under the bump rubber of the rear shock. Put some pressure on the rear wheel before tightening the link.

WARNING! SHORTEN THE SIDE-STAND 20-25mm.

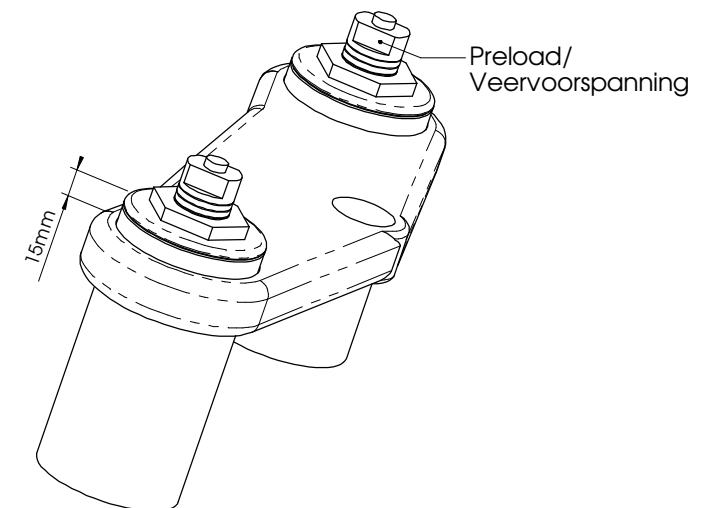

See WWW.HYPERPRO.COM for more info about our products.