

HYPERPRO

LOWERING KIT / VERLAGINGSSET

for

YAMAHA BT 1100 Bulldog Models '01>

LK-YA11-001-40 PART LIST

PR121380 - Pull rod/ trekstang	2
SL144410 - Stroke limiter/ slagbeperker	1
-	-
-	-

ALL IDEAS, DESIGNS, ARRANGEMENTS AND PLANS INDICATED OR REPRESENTED BY THIS DRAWING ARE OWNED BY HYPERPRO AND WERE CREATED, EVOLVED AND DEVELOPED FOR USE ON AND IN CONNECTION WITH THE SPECIFIC PROJECT. NONE SUCH IDEAS, DESIGNS, ARRANGEMENTS OR PLANS SHALL BE USED BY OR DISCLOSED TO ANY PERSON, FIRM OR CORPORATION FOR ANY PURPOSE WHATSOEVER WITHOUT THE WRITTEN PERMISSION OF HYPERPRO.

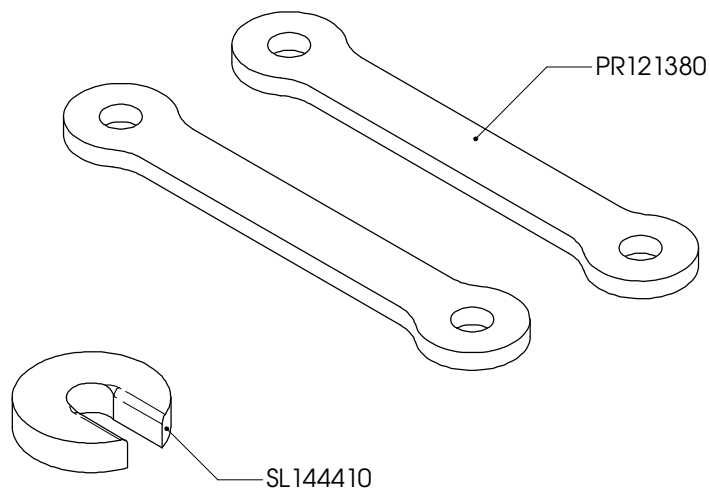

Inbouw handleiding

VOORZIJD

De vorkpoten maximaal 15 mm door de bovenste kroonplaat heen steken. De veer-voorspanning minimaal zetten (tegen de klok in draaien). De luchtkamer reduceren als de vork wil doorslaan.

ACHTERZIJD

De bestaande trekstangen vervangen door de HYPERPRO trekstangen. De slagbeperker onder het aanslagrubber van de achterschokbreker plaatsen. De sluitring van de bout bij de onderste gaffel van de schokbreker verwijderen. De bout zo inkorten dat hij nog 2mm door de moer steekt. Het achterwiel eerst belasten voordat de link vastgezet wordt.

LET OP! DE LENGTE VAN DE ZIJSTANDAARD MOET 20-25mm INGEKORT WORDEN.

Instruction manual

FRONT

Mount the fork legs max 15mm through the triple clamp. Turn the preload adjuster to minimum preload (counter clockwise). Reduce the air chamber if the fork hits the end of its stroke.

REAR

Replace the original pull rods with the HYPERPRO lowering pull rods. Put the stroke limiter under the bump rubber of the rear shock. Remove the washer from the bottom pitch fork. Shorten the bolt from the bottom pitch fork so much that it sticks just 2mm out of the nut. Put some pressure on the rear wheel before tightening the link.

WARNING! SHORTEN THE SIDE-STAND 20-25mm.

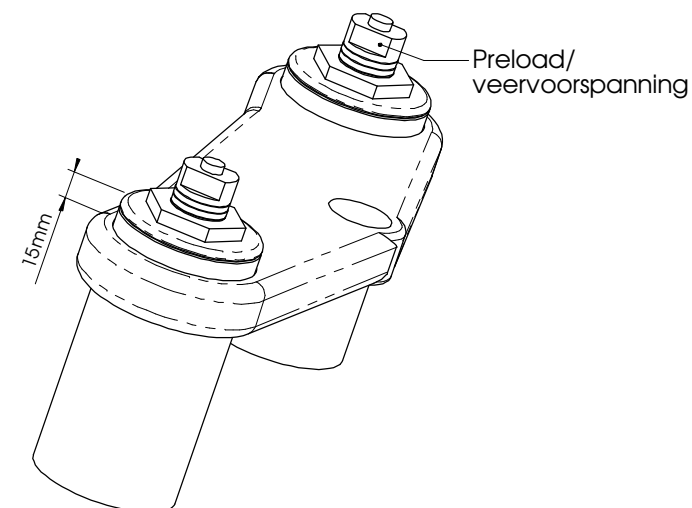

See WWW.HYPERPRO.COM for more info about our products.