

HYPERPRO

LOWERING KIT / VERLAGINGSSET for HYOSUNG GT 125 Naked Models '03>

LK-HY01-001-40 PART LIST

PR141260 - Pull rod / trekstang	2
Washers / ringen M14	2
SL124408 - Stroke limiter / slagbeperker	1
-	-

ALL IDEAS, DESIGNS, ARRANGEMENTS AND PLANS INDICATED OR REPRESENTED BY THIS DRAWING ARE OWNED BY HYPERPRO AND WERE CREATED, EVOLVED AND DEVELOPED FOR USE ON AND IN CONNECTION WITH THE SPECIFIC PROJECT. NONE SUCH IDEAS, DESIGNS, ARRANGEMENTS OR PLANS SHALL BE USED BY OR DISCLOSED TO ANY PERSON, FIRM OR CORPORATION FOR ANY PURPOSE WHATSOEVER WITHOUT THE WRITTEN PERMISSION OF HYPERPRO.

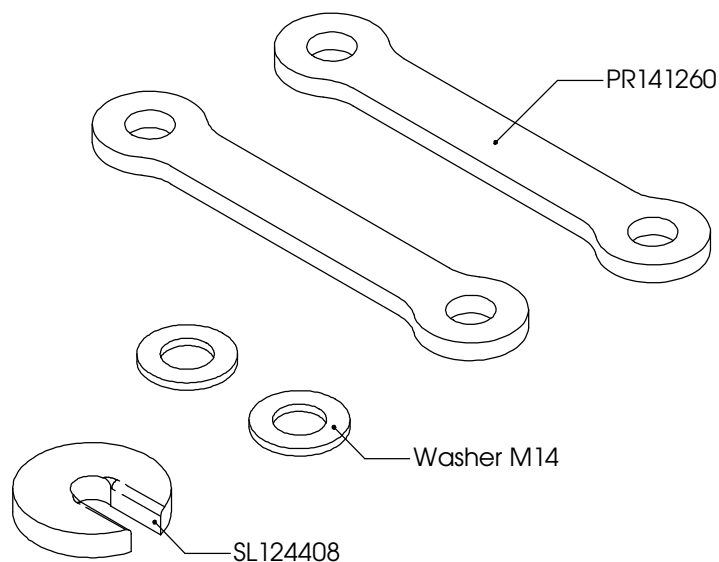

Inbouw handleiding

VOORZIJDE

De vorkpoten maximaal 23 mm door de bovenste kroonplaat heen steken.

ACHTERZIJDE

De bestaande trekstangen vervangen door de HYPERPRO trekstangen. Gebruik de ringen om het verschil in materiaaldikte uit te vullen. De slagbeperker BOVEN op het aanslagrubber van de achterschokdemper monteren. Het achterwiel eerst belasten voordat alles vastgezet wordt.

LET OP! DE LENGTE VAN DE ZIJSTANDAARD MOET ± 25 mm INGEKORT WORDEN.
AFTERMARKET ACHTERSPATBORDEN KUNNEN NIET MEER WORDEN TOEGEPAST.

Instruction manual

FRONT

Mount the fork legs max 23mm through the triple clamp.

REAR

Replace the original pull rods by the HYPERPRO lowering pull rods. Use the washers to compensate the difference in material thickness. Place the stroke limiter ON TOP of the bump-rubber of the rear shock. Put some pressure on the rear wheel before fully tightening all the bolts.

WARNING! SHORTEN THE SIDE-STAND ± 25 mm.
AFTERMARKET REAR MUDGUARDS CAN NO LONGER BE USED.

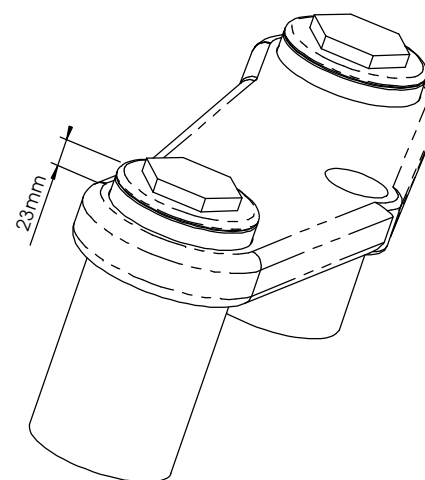

See WWW.HYPERPRO.COM for more info about our products.