

HYPERPRO

LOWERING KIT / VERLAGINGSSET

for

KAWASAKI ZX6-R (636) NINJA Models '05-'06

LK-KA06-006-40 PART LIST

PR121940 - Pull rods/ trekstangen	2
SL144711 - Stroke limiter/ slagbeperker	1
SL254711 - Stroke limiter/ slagbeperker	1
-	-

ALL IDEAS, DESIGNS ARRANGEMENTS AND PLANS INDICATED OR REPRESENTED BY THIS DRAWING ARE OWNED BY HYPERPRO AND WERE CREATED, EVOLVED AND DEVELOPED FOR USE ON AND IN CONNECTION WITH THE SPECIFIC PROJECT. NONE SUCH IDEAS, DESIGNS, ARRANGEMENTS OR PLANS SHALL BE USED BY OR DISCLOSED TO ANY PERSON, FIRM OR CORPORATION FOR ANY PURPOSE WHATSOEVER WITHOUT THE WRITTEN PERMISSION OF HYPERPRO.

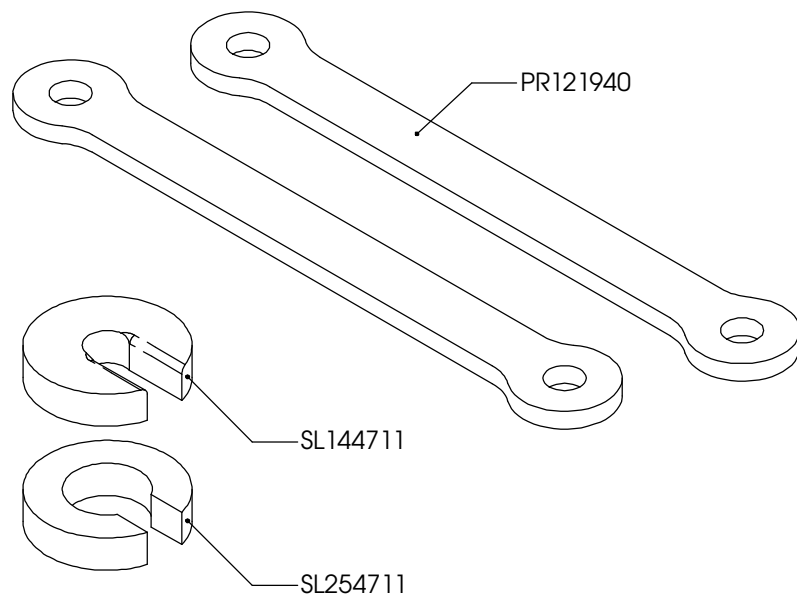

Inbouw handleiding

VOORZIJD

De vorkpoten maximaal 17 mm door de bovenste kroonplaat heen steken. De veer-voorspanning minimaal zetten (tegen de klok in draaien). De luchtkamer reduceren als de vork will doorslaan.

ACHTERZIJD

Verwijder de bestaande trekstangen en verwijder de schokdemper. Halveer de dikte van het bumprubber en verwijder de onderste helft. Plaats de slagbeperkers onder de overgebleven helft van het bumprubber. Monteer de schokdemper en de HYPERPRO trekstangen. Het achterwiel eerst belasten voordat de link vastgezet word.

LET OP! DE LENGTE VAN DE ZIJSTANDAARD MOET 25-30mm INGEKORT WORDEN. AFTERMARKET ACHTERSPATBORDEN KUNNEN NIET MEER WORDEN TOEGEPAST.

Instruction manual

FRONT

Mount the fork legs max 17mm through the triple clamp. Turn the preload adjuster to minimum preload (counter clockwise). Reduce the air chamber in the fork if necessary.

REAR

Remove the original pull rods and the shock. Cut the bump rubber in half and remove the lower half. Place the stroke limiters under the remaining half of the bump rubber. Install the shock and the HYPERPRO lowering pull rods. Put some pressure on the rear wheel before tightening the link.

WARNING! SHORTEN THE SIDE-STAND 25-30mm. AFTERMARKET REAR MUDGUARDS CAN NO LONGER BE USED.

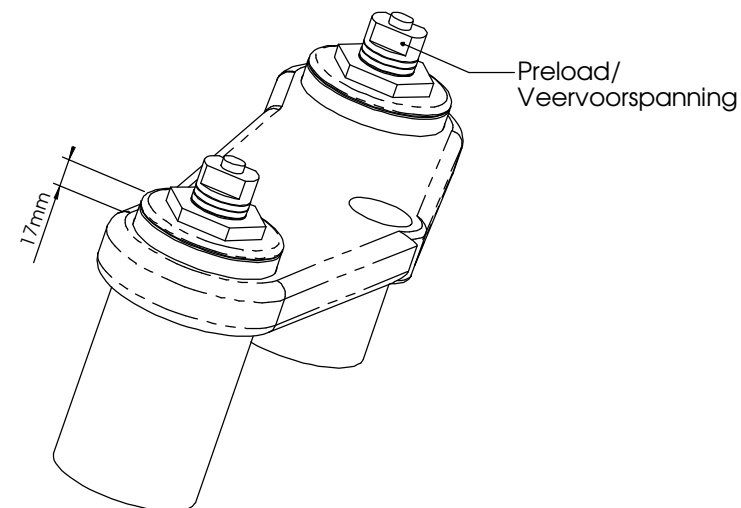

See WWW.HYPERPRO.COM for more info about our products.