

HYPERPRO

LOWERING KIT / VERLAGINGSSET

for

SUZUKI GSX-R 600 (WVBG) Models '01>

LK-SU06-005-40 PART LIST

PR121800 - Pull rods/ trekstangen	2
-	-
-	-
-	-

ALL IDEAS, DESIGNS, ARRANGEMENTS AND PLANS INDICATED OR REPRESENTED BY THIS DRAWING ARE OWNED BY HYPERPRO AND WERE CREATED, EVOLVED AND DEVELOPED FOR USE ON AND IN CONNECTION WITH THE SPECIFIC PROJECT. NONE SUCH IDEAS, DESIGNS, ARRANGEMENTS OR PLANS SHALL BE USED BY OR DISCLOSED TO ANY PERSON, FIRM OR CORPORATION FOR ANY PURPOSE WHATSOEVER WITHOUT THE WRITTEN PERMISSION OF HYPERPRO.

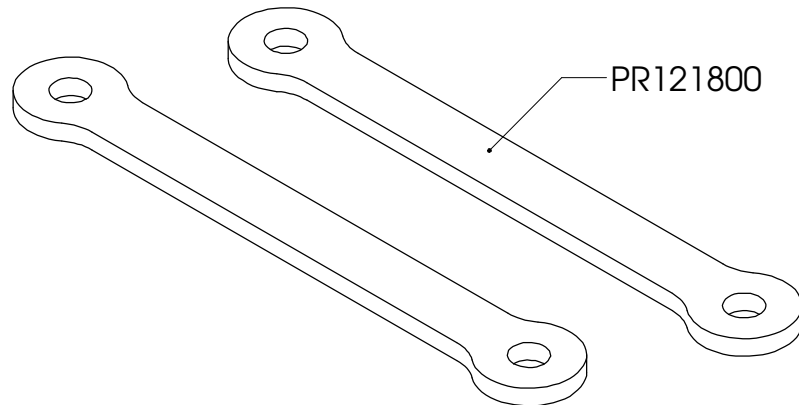

Inbouw handleiding

VOORZIJD

De vorkpoten maximaal 10 mm door de bovenste kroonplaat heen steken. De veer-voorspanning minimaal zetten (tegen de klok in draaien).

ACHTERZIJD

De link en de schokbreker demonteren. Verminder de originele veervoorspanning met min 7mm (voorspanning ring tegen de klok in draaien). De schokbreker weer monteren. De bestaande link vervangen door de HYPERPRO verlagingslink. Het achterwiel eerst belasten voordat de link vastgezet wordt.

LET OP! DE LENGTE VAN DE ZIJSTANDAARD MOET 25-30mm INGEKORT WORDEN.

Instruction manual

FRONT

Mount the fork legs max 10mm through the triple clamp. Turn the preload adjuster to minimum preload (counter clockwise).

REAR

Remove the link and the shock. Decrease the original spring preload with 7mm (turn preload ring counter clockwise) and install the shock. Replace the original link by the HYPERPRO lowering link. Put some pressure on the rear wheel before tightening the link.

WARNING! SHORTEN THE SIDE-STAND 25-30mm.

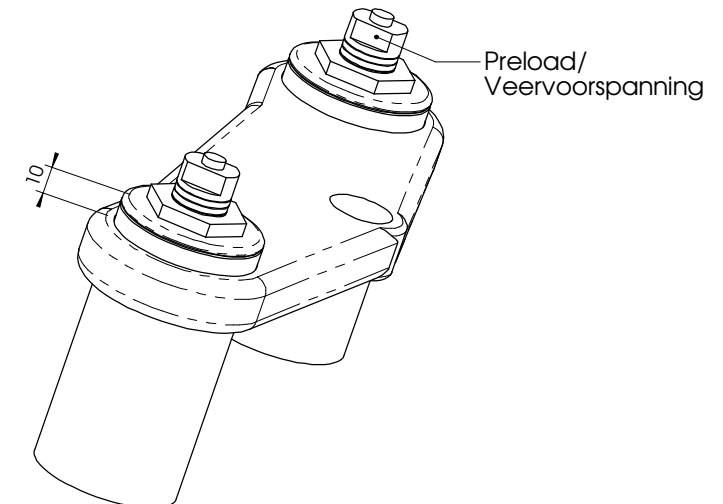

See WWW.HYPERPRO.COM for more info about our products.