

Adjustments

⚠ Warning!

Before riding, always make sure that the basic settings made by Öhlins are according to recommended Set-up Data. Read about adjustments and setting up in the Öhlins Owner's Manual before you make any adjustments. Contact an Öhlins dealer if you have any questions about setting up the shock absorber.

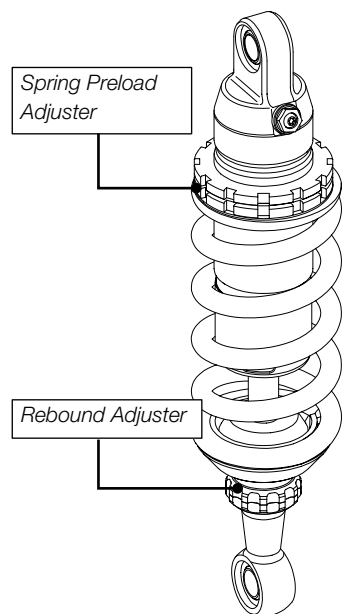

Set-up Data

Recommended set-up

Spring Preload	17 mm
Rebound	10 clicks
Total length	495 mm
Stroke	80 mm
Spring	00698-24
Spring rate	80N/mm
Spring; Free length	230 mm

👁 Read about Free Sag and Ride height in the Öhlins Owner's Manual.

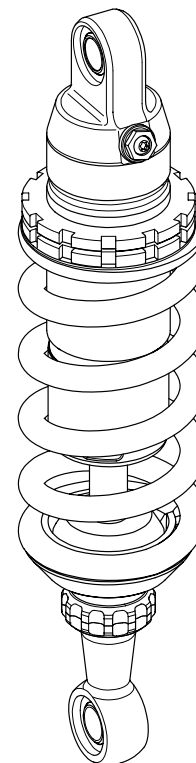

Before installing this product, check the contents of the kit. If anything is missing, please contact an Öhlins dealer.

Kit Contents

	Part No.	Pcs.
Shock absorber	BM 051	1
Öhlins Sticker	00192-01	2
O-ring	00438-57	2
C-spanner	00710-02	1
Spacer	00838-10	2
Memo Notes Sticker	01180-01	1
Owner's Manual	07251-02	1

👁 Note!

Please note that during storage and transportation, especially at high ambient temperature, some of the oil and grease used for assembling may leak and stain the packaging. This is in no way detrimental to the product, wipe off the excessive oil/grease with a cloth.

⚠ Warning!

Before installing this product, read the Öhlins Owner's Manual. The shock absorber is an important part of your vehicle and will affect the stability.

👁 Öhlins products are subject to continuous improvement and development, therefore, although these instructions include the most up-to-date information available at the time of printing, minor updates may occur.

To find the latest information contact your Öhlins distributor. Please consult your Öhlins dealer if you have any questions regarding the contents in this document.

Part no. BM 051_0
Issued 2010-11-03



© Öhlins Racing AB. All rights reserved. Any reprinting or unauthorized use without the written permission of Öhlins Racing AB is prohibited.

Öhlins Racing AB
Box 722
S-194 27 Upplands Väsby, Sweden
Phone +46 8 590 025 00
fax +46 8 590 025 80



www.ohlins.com

Shock Absorber for BMW R80/100GS/PD

BM 051

Mounting Instructions



How to install

⚠ Warning!

It is advisable to have an Öhlins dealer install the shock absorber.

When installing, consult your Vehicle Service Manual.

⚠ Warning!

Make sure the vehicle is securely supported so that it will not tip.

1
Put the motorcycle on a workstand so that the rear wheel barely touches the ground.

2
Remove the right side cover and the seat.

3
Remove the lower attachment of the original shock absorber.

⚠ Caution!

When the shock absorber is removed the rear wheel must be supported.

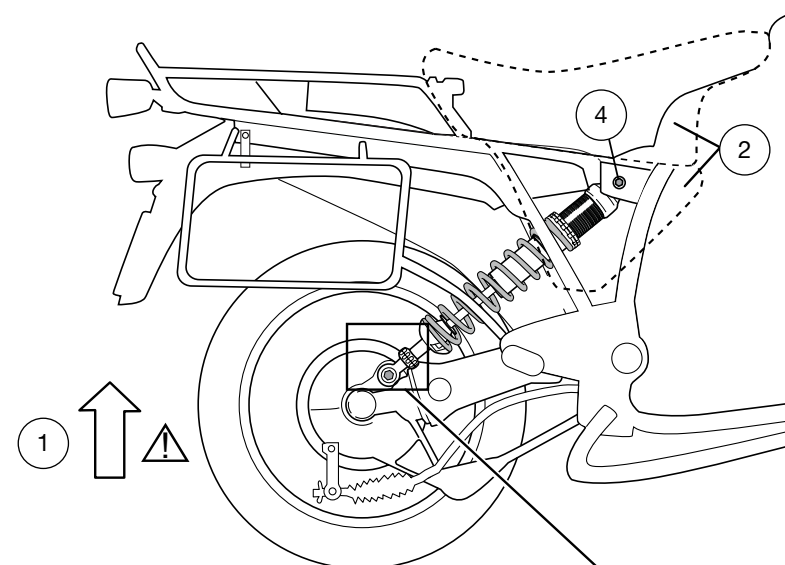
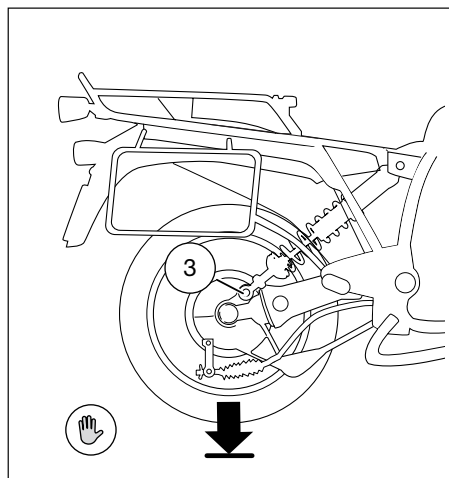

- 4**
Remove the upper attachment and remove the original shock absorber.
- 5**
Install the Öhlins shock absorber. The cylinder head should be at the top. Install the o-rings and spacers to the lower attachment, use the original bolt.

👁 Note!

Lift the rear wheel slightly to fasten the lower attachment.

6
Install the upper attachment. Use the original bolt.

7
Reattach the side cover and the seat.

👁 Note!

Make sure that all bolts are tightened to the correct torque and that nothing fouls or restricts movement of the shock absorber when the suspension is being fully compressed or extended.

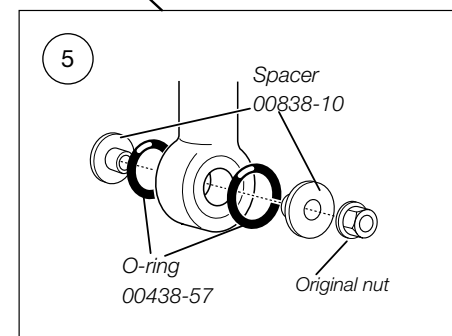

8
Read more about the shock absorber, sag, ride height and the different settings in your Öhlins Owners Manual.