

Adjustments

⚠ Warning!

Before riding, always make sure that the basic settings made by Öhlins are according to recommended Set-up Data. Read about adjustments and setting up in the Öhlins Owner's Manual before you make any adjustments. Contact an Öhlins dealer if you have any questions about setting up the shock absorber.

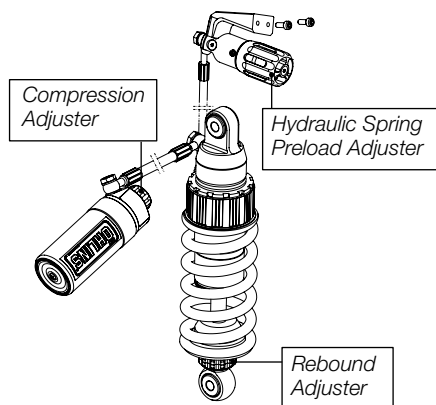

Set-up Data

Recommended Set-up

Spring preload	25 mm
Rebound damping	14 clicks
Compr. damping	12 clicks

Shock Absorber Data

Shock absorber length	295 mm
Stroke	58 mm

Spring

Part No.	Rate
01092-24	80 N/mm
Free spring length	170 ±3 mm

Recommended Sag and Ride Height

R1 - R2:	8 mm
R1 - R3:	32 mm
F1 - F2:	18 mm
F1 - F3:	27 mm

👁 Read more about sag and ride height in the Öhlins Owner's Manual.

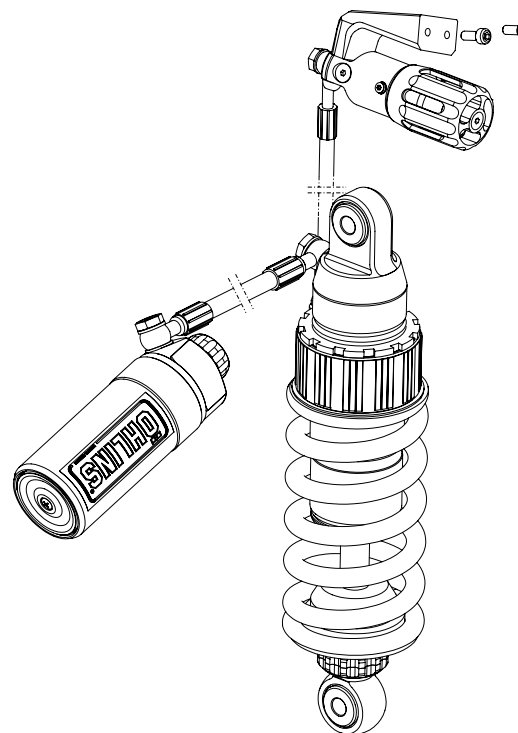

Before installing this product, check the contents of the kit. If anything is missing, please contact an Öhlins dealer.

Kit Contents

	Part No.	Pcs.
Shock absorber	DU110	1
Öhlins Sticker	00192-01	2
Tie rap	00231-01	2
Screw M 5x12	01046-34	2
Memo Notes Sticker	01180-01	1
Owner's Manual	07241-02	1

Please note that during storage and transportation, especially at high ambient temperature, some of the oil and grease used for assembling may leak and stain the packaging. This is in no way detrimental to the product, wipe off the excessive oil/grease with a cloth.

⚠ Warning!

Before installing this product, read the Öhlins Owner's Manual. The shock absorber is an important part of your vehicle and will affect the stability of your vehicle.

👁 Öhlins products are subject to continuous improvement and development, therefore, although these instructions include the most up-to-date information available at the time of printing, minor updates may occur.

To find the latest information contact your Öhlins distributor. Please consult your Öhlins dealer if you have any questions regarding the contents in this document.

Part no. DU110_0
Issued 2011-04-28



Shock Absorber for Ducati Diavel

DU 110

Mounting Instructions

© Öhlins Racing AB. All rights reserved. Any reprinting or unauthorized use without the written permission of Öhlins Racing AB is prohibited.

Öhlins Racing AB
Box 722
S-194 27 Upplands Väsby, Sweden
Phone +46 8 590 025 00
fax +46 8 590 025 80



www.ohlins.com



⚠ Warning!

It is advisable to have an Öhlins dealer install the shock absorber.

⚠ Warning!

Make sure the vehicle is securely supported so that it will not tip.

⚠ Warning!

When installing, read the Vehicle Service Manual

1

Put the motorcycle on a workstand so that the rear wheel barely touches the ground. The motorcycle must be supported so that you can remove the swing arm axle and move the swing arm slightly towards the rear.

2

Remove the rear fender and the front under tray cover.

3

Loosen the chain tension as much as possible. Remove the front sprocket cover.

4

Remove the silencer and the exhaust collector tube.

5

Remove the original pre-load adjuster bracket.

6

Loosen the gas reservoir bracket.

7

Loosen the engine mounting bolt over the swing arm axle. Support the the swing arm so that you can remove the swing arm axle. Remove the plastic cover for the cables on the right side of the swing arm, closest to the swing arm axle.

8

Remove the front pull rod-shock absorber bracket axles. Remove the rear shock absorber mounting bolt.

9

Reduce the chain tension as much as possible. Remove the swing arm axle and move the swing arm slightly forward to hook off the chain from the rear sprocket.

10

Move the swing arm slightly towards the back.

⚠ Caution!

Be careful not to damage the brake lines or cables on the right side of the swing arm.

👁 Note!

Ensure not to lose the washer/s on the left side.

11

Remove the pre-load adjuster hose bracket in front of the swing arm. Pull out the shock absorber and pre-load adjuster from below.

👁 Note!

Before installing the Öhlins shock absorber clean the vehicle thoroughly.

12

Use the original reservoir bracket without the rubber on the Öhlins reservoir.

13

Use the pre-load adjuster hose bracket to the Öhlins shock absorber hose by cutting the rubbers and opening the wires slightly. Close the wires before inserting the rubber guides. You will get best result if you glue the rubbers together again, use super glue or similar.

14

Put the Öhlins shock absorber in place by pulling the pre-load adjuster up to its standard position in the same way as the original adjuster was mounted. Mount the hose bracket in the front of the swing arm.

15

Mount and tighten the rear shock absorber bracket.

16

Push the swing arm forward carefully and put the chain back on the rear sprocket. Pull the swing arm back into its normal position and mount the swing arm axle.

⚠ Caution!

Be careful not to damage the brake lines or cables on the right side of the swing arm.

👁 Note!

Remember the washer on the left side.

17

Tighten the swing arm axle and the engine mounting bolt that was loosened earlier.

18

Mount the pull rod-front shock absorber axle and tighten.

19

Mount the pre-load adjuster bracket with the supplied screws 01046-34.

20

Mount the front sprocket cover. Put the cable ties back in place, if removed.

21

Mount the gas reservoir in the same position as the standard reservoir. Mount the cable cover on the front right side of the swing arm.

22

Mount the exhaust collector, under tray cover, rear fender and silencer.

23

Adjust the chain tension according to your vehicle service manual and tighten the adjuster lock screws.

⚠ Caution!

Make sure that all screws are tightened to the correct torque and that nothing fouls or restricts movement of the shock absorber when the suspension is fully compressed or extended.

