

Setup data

Shock absorber length	305 mm
Shock absorber stroke	66 mm
Spring preload	17 mm
Rebound damping adjuster	14 clicks

Checking sag and ride height

Front suspension

F1. Bike on a stand with the suspension fully extended =

F2. Bike on the ground without rider =

F3. Bike on the ground with rider =

Free sag F1 - F2 =

Ride height F1 - F3 =

Rear suspension

R1. Bike on a stand with the suspension fully extended =

R2. Bike on the ground without rider =

R3. Bike on the ground with rider =

Free sag R1 - R2 =

Ride height R1 - R3 =

Mounting Instructions

Öhlins shock absorber kit
DU 321 for Ducati Monster



Öhlins shock absorber 46 DR

Your Öhlins shock absorber type 46 DR features the following adjusters:

Rebound damping adjuster

Adjuster wheel on the piston shaft above the end bracket.

Spring preload adjuster

Adjustments are made by turning the rings on the shock absorber body. Clockwise for harder adjustment, counter clockwise too release the preload.

NOTE!

When delivered the Öhlins shock absorber is dialed to recommended settings for the specific brand and make of the motorcycle. If you have changed the setting check like this:

The adjusters have a normal right hand thread. Turn the damping adjusters clockwise to fully closed (pos. zero [0]). Turn counter clockwise to open and count the clicks until you reach the recommended number of clicks. See Setup data at last page.

CAUTION!

Do not use too much force, delicate sealing surfaces can be damaged.



Öhlins Racing AB, Box 722, S-194 27 Upplands Väsby, Sweden.
Phone +46 8 590 025 00. Fax +46 8 590 025 80.
www.ohlins.com

DU 321_1 Issued 2010 06 30

© Öhlins Racing AB. All rights reserved. Any reprinting or unauthorized use without the written permission of Öhlins Racing AB is prohibited. Printed in Sweden.



Safety signals

Important information concerning safety is distinguished in this manual by the following notations:



*The Safety alert symbol means:
Caution! Your safety is involved.*

WARNING!

Failure to follow warning instructions could result in severe or fatal injury to anyone working with, inspecting or using the suspension, or to bystanders.

CAUTION!

Caution indicates that special precautions must be taken to avoid damage to the suspension.

NOTE!

This indicates information that is of importance with regard to procedures.

Before installation

Öhlins Racing AB can not be held responsible for any damage whatsoever to shock absorber or vehicle, or injury to persons, if the instructions for fitting and maintenance are not followed exactly.

Similarly, the warranty will become null and void if the instructions are not adhered to.

WARNING!

1. Installing a shock absorber, that is not approved by the vehicle manufacturer, may affect the stability of your vehicle. Öhlins Racing AB cannot be held responsible for any personal injury or damage whatsoever that may occur after fitting the shock absorber. Contact an Öhlins dealer or other qualified person for advice.

2. Please study and make certain that you fully understand all the mounting instructions and the owners manuals before handling this shock absorber kit. If you have any questions regarding proper installation procedures, contact an Öhlins dealer or other qualified person.

3. The vehicle service manual must be referred to when installing the Öhlins shock absorber

Öhlins products are subject to continual improvement and development. Consequently, although these instructions include the most up-to-date information available at the time of printing, there may be minor differences between your suspension and this manual. Please consult your Öhlins dealer if you have any questions with regard to the contents of the manual.

NOTE!

During storage and transportation, especially at high ambient temperature, the oil and grease used for assembling may run out inside the packing and damage the expanded polystyrene packing material. This is not unusual and is in no way detrimental to the shock absorber.

Kit contents

Before installing the shock absorber, please check the contents of the kit. If anything is missing, contact your Öhlins dealer.

Description	Pcs.	Part No.
Shock absorber 46 DR		DU 321
C-spanner	1	00710-02
Sticker Öhlins Racing AB	2	00192-01
Memo sticker	1	01180-01
Owners Manual	1	

Mounting Instructions

1

Put the motorcycle on a stand so the rear wheel is clear of the ground. Make sure it's steadily fixed so it will not fall over.

WARNING!

1. It's advisable to have an Öhlins dealer or other qualified person to fit your shock absorber.
2. Instructions in the vehicle service manual are to be followed when changing the shock absorber.
3. When working on a lifted vehicle it must be securely supported to prevent it from falling.

2

Remove the seat. (Not S4)

3

Remove the combined rear fender and chain cover. (Not S4)

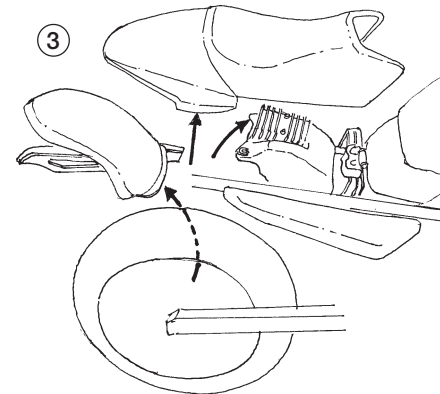

4

Loosen and lift the front edge of the unit containing the air cleaner and the cut out relay. (Not S4)

5

Remove the push rod of the rear brake cylinder to get access to the shock absorber attachment.

6

Remove the rubber cover on the right side of the swing arm.

7

Loosen the lower shock absorber attachment bolt with a 8 mm T-handle allen key.

NOTE!

Be careful not to drop the bolt into the swing arm.

8

Remove the upper shock absorber bolt.

9

Let the rear wheel down as much as possible and remove the standard shock absorber.

10

Mount the Öhlins shock absorber in reverse order.

11

Reassemble the rear brake cylinder by putting the pushrod back in position.

12

Continue your work according to the Owners manual, section adjustments.

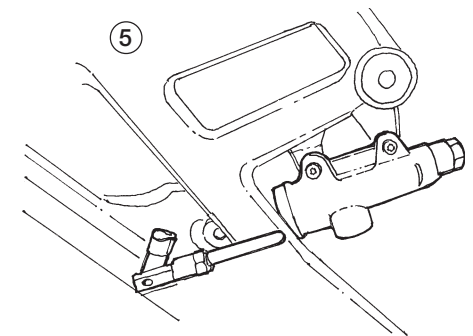

NOTE!

Make sure that all bolts are tightened to the correct torque and that nothing fouls or restricts movement of the shock absorber when the suspension is being fully compressed or extended. Check with the Workshop manual for the motorcycle.