

# SET-UP DATA

## Recommended set-up

Rebound ..... 12 clicks  
 Compression ..... 12 clicks  
 Spring Preload ..... 6 mm  
 Oil Level ..... 150 mm  
 Öhlins Front Fork Fluid ..... Part no 01309-01  
 Fork leg position ..... 12 mm

## Spring

Part No. .... Rate  
 04744-10 (standard) ..... 10 N/mm  
 04744-90 (optional) ..... 9,0 N/mm  
 04744-95 (optional) ..... 9,5 N/mm  
 04744-05 (optional) ..... 10,5 N/mm  
 04744-11 (optional) ..... 11 N/mm

## Recommended Sag and Ride Height

### No rider (Free sag)

Rear ..... 10-20 mm (R1-R2)  
 Front ..... 15-30 mm (F1-F2)

### With Rider (Ride height)

Rear ..... 25-40 mm (R1-R3)  
 Front ..... 35-50 mm (F1-F3)

AIR SPRING FOR ONE LEG

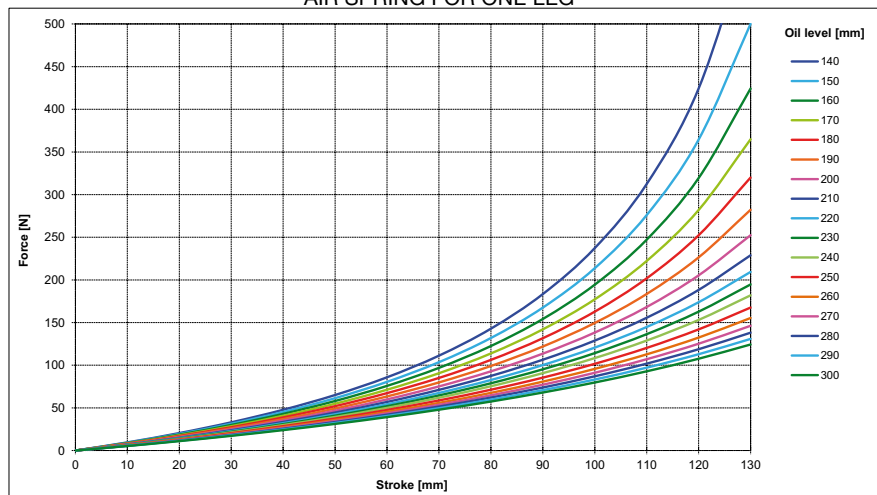

Before installing this product, check the contents of the kit. If anything is missing, please contact an Öhlins dealer.

## Kit Contents

	Part No	Pcs
Front fork	FGRT 213	1
Sticker Öhlins	01196-02	1
Owner's manual	07282-07	1

### Note!

Please note that this image is a general representation of the product and may differ slightly from your product.

### Note!

Please note that during storage and transportation, especially at high ambient temperature, some of the oil and grease used for assembling may leak and stain the packaging. This is in no way detrimental to the product, wipe off the excessive oil/grease with a cloth.

### Warning!

Before installing this product, read the Öhlins Owner's Manual. The shock absorber/front fork/steering damper is an important part of your vehicle and will affect the stability.

Öhlins products are subject to continuous improvement and development, therefore, although these instructions include the most up-to-date information available at the time of printing, minor updates may occur.

To find the latest information contact an Öhlins distributor. Please contact Öhlins if you have any questions regarding the contents in this document.

Part no. ML\_FGRT213\_0  
 Issued 2013-01-11



## Front fork for Ducati 848/1098/1198

# FGRT 213

## Mounting Instructions

© Öhlins Racing AB. All rights reserved. Any reprinting or unauthorized use without the written permission of Öhlins Racing AB is prohibited.

Öhlins Racing AB  
 Box 722  
 S-194 27 Upplands Väsby, Sweden  
 Phone +46 8 590 025 00  
 fax +46 8 590 025 80



www.ohlins.com



# MOUNTING INSTRUCTIONS

## ⚠ Warning!

It is advisable to have an Öhlins dealer install the shock absorber/front fork/steering damper.

## ⚠ Warning!

If working on a raised vehicle, ensure it is securely supported so that it will not tip.

## 👁 Note!

Before mounting this product clean the vehicle thoroughly.

## 👁 Note!

When working on this product, always see the Vehicle Service Manual for vehicle specific procedures and important data.

1

Put the motorcycle on a workstand so that the front wheel barely touches the ground.

## ⚠ Warning!

Make sure the vehicle is securely supported so that it will not tip.

2

Remove the front fender, brake caliper and the front wheel.

3

Measure the distance from the top of the outer fork leg to the top of the upper triple clamp.

## 👁 Note!

It is very important that the front fork is reattached at the exact same position.

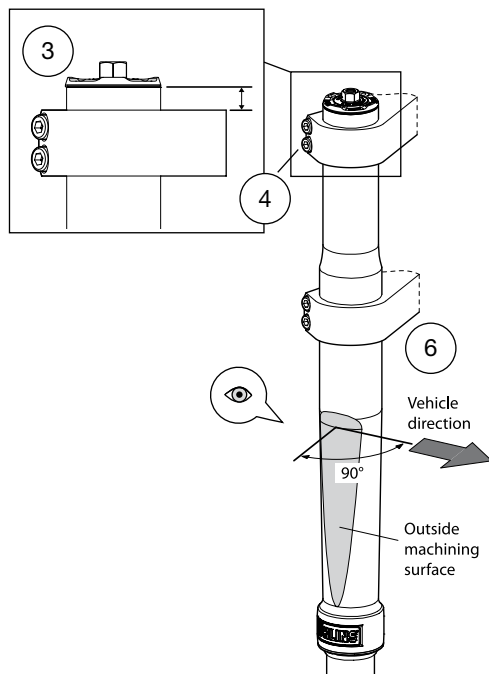
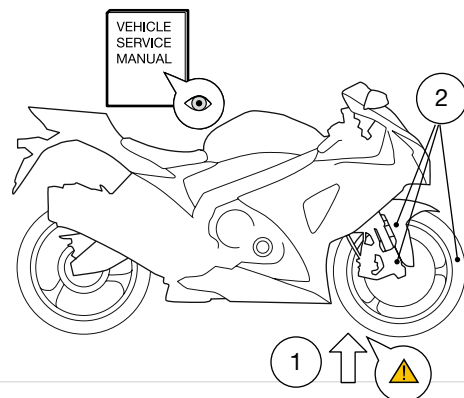

4

Loosen the upper and lower triple clamps by loosening the screws.

5

Remove the fork legs from the triple clamps.

6

Install the fork legs into the triple clamps at the same height as measured in step 3. Turn the handle bars fully from side to side to make sure that nothing restricts the movement, and that the throttle cable and wire harness runs in smooth bends.

## 👁 Note!

The surface of the outer machining must be 90° from the vehicle direction.

7

Tighten the triple clamps:  
Upper triple clamp 20 Nm  
Lower triple clamp 10 Nm

# MOUNTING INSTRUCTIONS

8

Reinstall the front fender, front wheel and the brake calipers. Do not tighten yet.

9

Put the vehicle on the ground, apply the front brake and compress the front fork distinctly 3-4 times. This will put the legs in an exact parallel position.

10

Tighten the front wheel, brake calipers and the front fender. Consult your Vehicle Service Manual for correct tightening torques.

11

Make sure that nothing restricts the fork movement when fully compressed. Read more about the front fork in the Öhlins Owner's Manual.

## 👁 Note!

In storage or transport the oil in the front fork can be displaced and therefore temporarily loses some of its damping performance.

12

Close the rebound and compression adjusters.

13

Repeatedly compress the front fork as much as possible to bleed the air out. Ensure there is damping on the full stroke.

14

Set the rebound and compression adjusters according to recommended set-up.

15

Read more in Öhlins Owners manual - Chapter Setting up your front fork, Extended stroke.

## 👁 Caution!

Ensure that all screws are tightened to the correct torque and that nothing fouls or restricts movement of the shock absorber/front fork/steering damper when the suspension is fully compressed or extended.

## Adjustments

### ⚠ Warning!

Before riding, always make sure that the basic settings made by Öhlins are according to recommended Set-up Data. Read the Öhlins Owner's Manual before you make any adjustments. Contact an Öhlins dealer if you have any questions about setting up the front fork.

