



Öhlins Fork Kit Adventure

FKA 100-series

Owner's Manual



ADVANCED SUSPENSION TECHNOLOGY



Öhlins Headquarters Upplands Väsby, Sweden

Öhlins Racing AB - The Story

It was the 1970's, a young man named Kenth Öhlin spent most of his spare time pursuing his favourite sport: motocross.

Being a careful observer, Kenth's attention was continuously drawn to one specific detail - motocross bikes had more engine power than their suspension could handle. It was not long before Kenth realised that better performance could be achieved by improved wheel suspension.

Öhlins Racing was established in 1976, and just two years later the company won its first World Championship title. Despite being in the business for 35 years, the search for perfection and new functions is still the main focus of the company.

Congratulations! You are now the owner of an Öhlins product. More than two hundred World Championships and other major world titles are definitive proof that Öhlins suspension offer outstanding performance and reliability.

Every product has gone through rigorous testing and engineers have spent thousands of hours, doing their very best to use every possible experience from our 35 years within the racing sport.

The product that you now have in your possession is pure racing breed that is built to withstand.

By installing this product on your vehicle you have made a clear statement... you are a serious rider with a focus on getting the maximal handling ability and outstanding feedback from your vehicle. Along comes the fact that your Öhlins product will be a long lasting friend, delivering the very best of comfort and performance every time you go for a ride. Go explore!

SAFETY PRECAUTIONS

General Warnings

Note!

The shock absorber/front fork/steering damper is an important part of the vehicle and will affect the stability.

Note!

Read and ensure you understand the information in this manual and other technical documents provided by Öhlins, before using the product.

Note!

Öhlins Racing AB can not be held responsible for any damage to the shock absorber/front fork/steering damper, vehicle, other property or injury to persons, if the instructions for mounting, usage and maintenance are not followed exactly.

Warning!

After installing the Öhlins product, take a test ride at low speed to ensure your vehicle has maintained stability.

Warning!

If the suspension makes an abnormal noise, or the function is irregular, or if you notice any leakage from the product, stop the vehicle immediately and return the product to an Öhlins dealer.

Warning!

The product warranty shall only apply if the product has been operated and maintained in accordance with recommendations in this manual. If you have any questions regarding usage, service, inspection and/or maintenance please contact Öhlins.

Note!

When working with the Öhlins product, always read the vehicle service manual.

Note!

This manual shall be considered as a part of the product and shall accompany the product throughout its life cycle.

SAFETY SYMBOLS

In this manual, mounting instructions and other technical documents, important information concerning safety is distinguished by the following symbols:



The Safety Alert Symbol means: Warning! Your safety is involved.

Warning!

The Warning Symbol means: Failure to follow warning instructions can result in severe or fatal injury to anyone working with, inspecting or using the product, or to bystanders.



Caution!

The Caution Symbol means: Special precautions must be taken to avoid damage to the product.

Note!

The Note Symbol indicates information that is important regarding procedures.

Product Specific Warnings

Warning!

This product was developed and designed exclusively for a specific vehicle model and shall only be installed on the intended vehicle model in its original condition as delivered from the vehicle manufacturer.

CONTENTS

1 Design.....	4
2 Oil	7
2.1 Fill Oil and Aerate.....	7
2.2 Measure Oil Level.....	7
3 Setup	8
4 Adjusters	9
5 Change Spring and/or Oil Level	10
6 Inspection and Maintenance	11

1 DESIGN

Congratulations on your choice of purchasing the Öhlins cartridge kit for adventure bikes! The medium sized adventure bikes used in their right element on true adventures, both on and off the road, can now enjoy the improved comfort and performance from an Öhlins cartridge kit. The Öhlins R&D decided to go for a solution based on the successful Öhlins NIX technology to develop a cartridge kit that offers comfort and performance, and will work long between service intervals. The cartridge kit is designed to fit easily in the upside down forks most adventure bikes are equipped with today. Thanks to these new FKA100 kits the adventure bikes now have a fully adjustable front end.

The Öhlins front fork cartridge kit consists of one compression cartridge and one rebound cartridge. Install the compression cartridge in the left front fork leg and the rebound cartridge in the right front fork leg. The cartridges are marked at the top cap, COMP for compression adjustment and REB for rebound adjustment.

Brief Description

The compression and rebound cartridges are largely identical but work in opposite ways. In the compression cartridge there is a base valve installed in the adaptor. To achieve rebound damping instead of compression damping force, the cylinder tubes and the main pistons are positioned in opposite directions in the compression and rebound cartridges.

When the front fork moves, the fluid inside is forced to flow through the compression and rebound main pistons and the compression base valve.

At a compression movement the fluid is forced through the compression shim stack, the compression base valve shim stack and at the same time through the rebound check valve.

At a rebound movement the fluid is forced through the rebound shim stack and through the compression check valve.

The fluid displaced by the piston shafts is directed either into or out of the cylinder tubes through the holes.



1 DESIGN

Main Piston

Bleed valve

Compression and rebound damping

Small needle valve that creates a flow restriction simply by being small.

Shim valve

Compression and rebound damping

Fluid pressure has to deflect thin steel washers (shims) to open up an orifice and allow fluid to flow through it.

Check valve

Compression and rebound damping

A spring preloaded shim that opens easily, for return flow of fluid when the direction of movement of the front fork changes.

Base valve

Shim valve

Compression damping only

Fluid pressure has to deflect thin steel washers (shims) to open up an orifice and allow fluid to flow through it.

Function

The bleed valve and shim valve are used to build up damping force. At slow stroke speeds, the percentage going through the bleed valve is higher, and at fast strokes the shim valve takes care of most of the flow.

The compression main piston shim valve works together with the compression base shim valve. Most of the oil flows through the main piston and at higher speed the base valve opens for oil flow.

The check valve, together with the bleed valve (since it can flow both directions), handle return flows.

To control damping force the bleed valve can be changed by the external compression and rebound adjuster.

Action characteristics can be changed by altering the stiffness of the shim stack, number of shims, shim thickness, diameter and shape. *Altering the shim stack should only be performed by an authorized Öhlins dealer.*

Oil lock

During the last part of the stroke the oil lock piston enters the oil lock cup which gives a firmer damping.

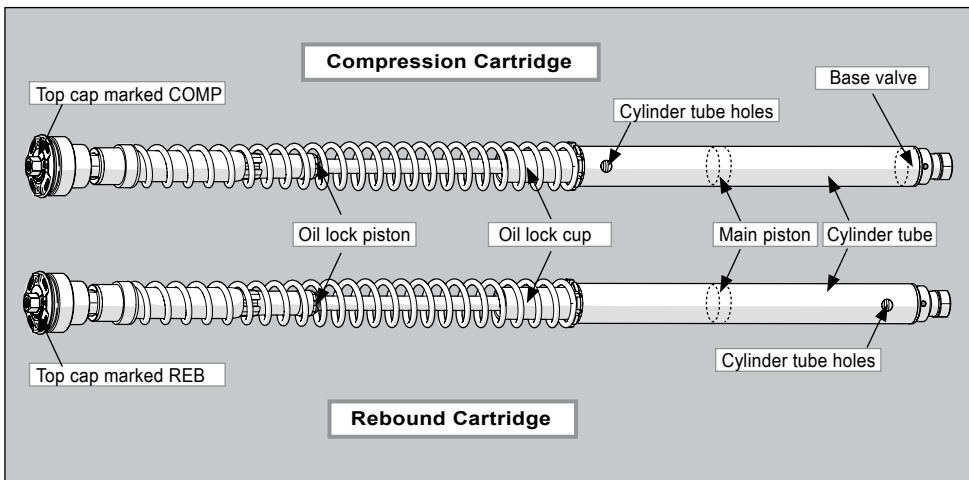

1 DESIGN

Oil Level

The upside down front forks are very sensitive to oil level variations compared to the conventional front fork types. Therefore, adjust the oil level with special care. A change in the front fork oil level will not affect the air spring force in the early stage of the movement, but will have a greater effect in the later stage.

Oil level Diagram

The diagram below shows two different types of curves for the force that equals to a specific oil level.

Raised Oil Level

The air spring in the later half stage of travel is stronger which makes the front fork *firmer*.

Lowered Oil Level

The air spring in the later half stage of travel is lessened which makes the front fork *softer*.

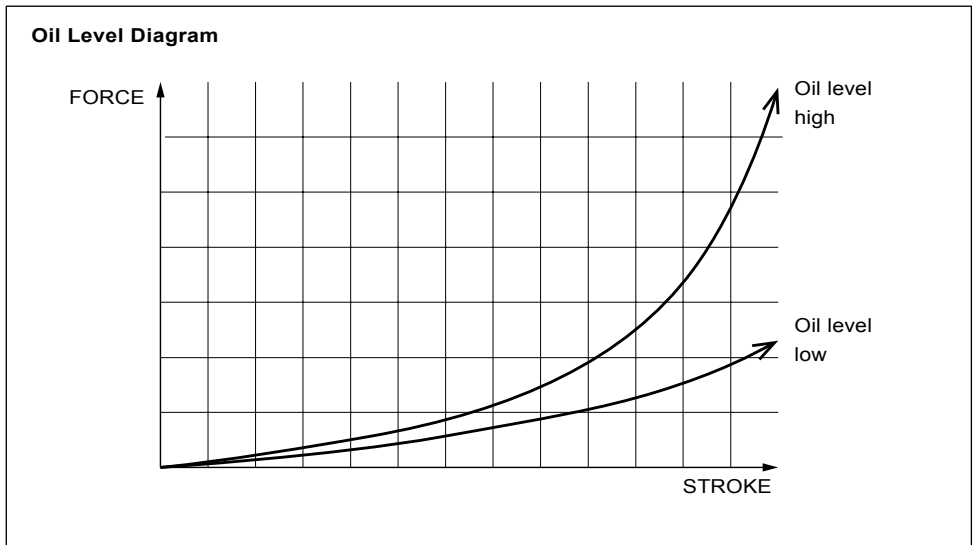

2 OIL

2.1 Fill Oil and Aerate

⚠ Warning!

Always aerate the damping system after changing/ adding oil. Air in the system may cause poor or no function at all.

👁 Note!

The following process applies to: cartridge kit installed in the fork legs without spring support, guide sleeve or spring.

2.1.1

Make sure the shaft assembly is in bottom position. Pour Öhlins front fork fluid into the fork leg. Fill up so that the oil level is above the top of the seal head during the aeration process.

👁 Note!

Note that the oil level drops during the aeration process since the air goes out of the system.

2.1.2

Open the adjusters fully. Install the top cap directly to the shaft extension (No spring, guide sleeve or spring support).

2.1.3

Pull up the outer tube and tighten it to the top cap. Hand tighten only. Make sure that the fork leg is fully extended.

2.1.4

Close the adjusters fully and pump out all air from the damping system by pulling the outer tube up and down, from fully extended to fully compressed, ~ 15-20 times.

2.1.5

→ If aeration process was successful, continue with step 2.2 Measure Oil Level.

→ If after aerating, the oil level is below the top of the seal head, fill up with more oil and repeat the aeration process. *If the oil level is below the top of the seal head there may be air trapped in the damping system which may cause poor or no function at all.*

2.2 Measure Oil Level

Make sure that the shaft assembly is in the bottom of the fork leg and that the outer tube is in its bottom position. Measure the oil level with a ruler. See figure. For recommended oil level, see the Mounting Instructions or contact an Öhlins dealer. Add or remove oil to adjust to the recommended level.

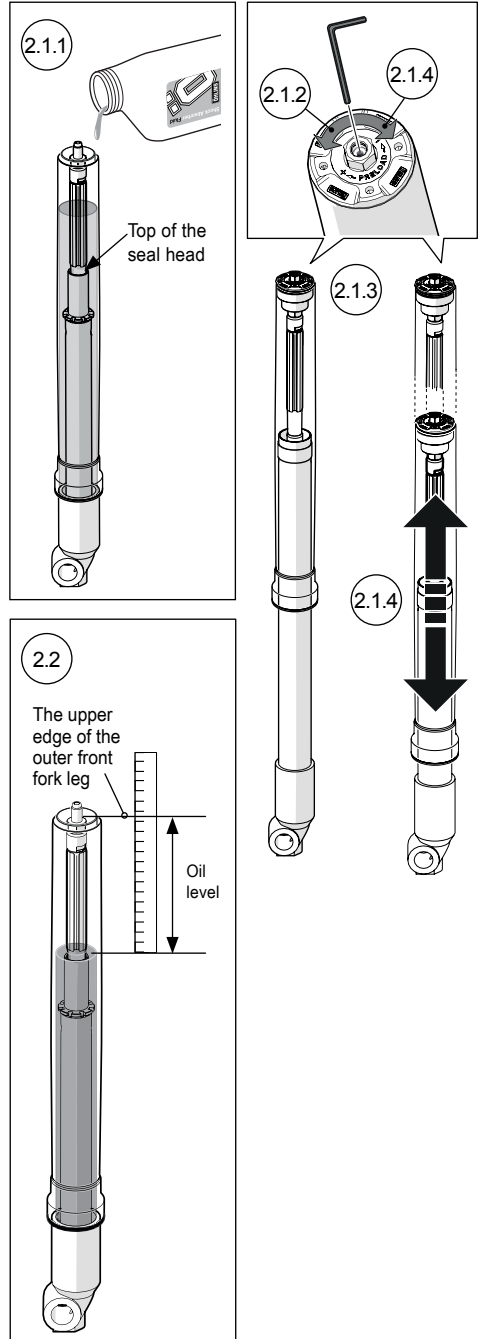

3 SET UP

3.1 Measure Sag

Spring Preload - Free Sag - Ride Height

Spring preload is a crucial part of setting your motorcycle since it affects the height of the motorcycle and the fork angle. Before setting the preload, measure the sag:

👁 Note!

The following procedure should be performed on a flat surface.

1. Put the motorcycle on a work stand so that both wheels are off the ground and the suspension is unloaded.
2. Mark, for example with a piece of tape, a point immediately above the rear wheel axle.
3. Measure the distance from the marked point to a fixed point, for example the wheel axle (R1).
4. Measure the distance from the bottom of the upper triple clamp to a fixed point, for example the front wheel axle (F1).
5. Put the motorcycle on the ground so that the front and the rear suspensions are slightly compressed. Repeat the measuring procedures (R2 and F2).
6. Sit on the motorcycle in normal riding position, properly outfitted in your riding gear. Repeat the measuring procedure (R3 and F3).

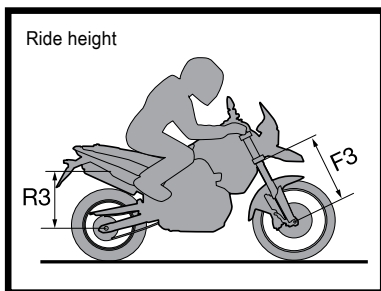
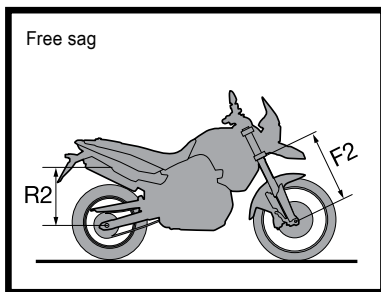
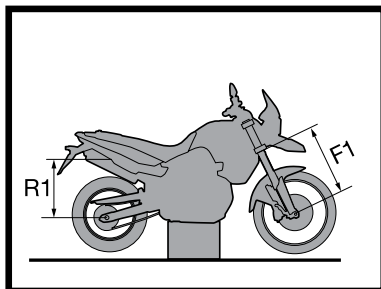

Note measures			
R1		F1	
R2		F2	
R3		F3	

Recommended Measures

If no other recommendations are given in the Mounting Instructions follow these measures:

Sag pos.	Formula	Rec.
Free sag	$\frac{(F1-F2)}{\text{wheel travel}} \times 100$	~15-30 %
Ride height	$\frac{(F1-F3)}{\text{wheel travel}} \times 100$	~20-40 %

3.2 Adjust spring preload

1. If your measures differ significantly from the recommendations, adjust the spring preload. (See chapter Spring Preload in this manual).
2. If the ride height still differs from the recommendations, you may need to change to softer/harder spring. Contact an Öhlins dealer for advice.

⚠ Warning!

Incorrect spring rate may result in a front geometry that is either too steep or too flat. This can result in a tendency of under or over steering, that could seriously affect the handling characteristics of the motorcycle.

4 ADJUSTERS

⚠ Warning!

Before riding, always ensure that the basic settings made by Öhlins are intact. Make only one adjustment at a time, adjust in small steps and take notes.

👁 Note!

For recommended setup see the Mounting Instructions or contact an Öhlins dealer.

Spring preload adjuster

To turn the adjuster use a 14 mm wrench. One [1] turn equals 1 mm change in spring preload. Turn the adjuster counter clockwise to fully closed position (zero [0]). Then, turn clockwise and count the turns until you reach the desired number.

Adjustment range 0-18 mm.

Compression damping adjuster

Left front fork leg.

Rebound damping adjuster

Right front fork leg.

Adjust Compression and Rebound

To adjust, turn the adjuster using a 3 mm Allen key. Turn the adjuster clockwise to fully closed position (zero [0]). Then, turn counter clockwise to open, and count the clicks until you reach the recommended number of clicks.

Adjustment range from fully closed valve to fully open valve is ~24 clicks.

👉 Caution!

Turn gently not to damage delicate sealing surfaces. Hand tighten only.

Spring preload adjuster

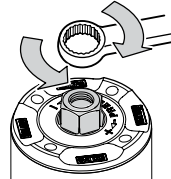

Compression damping adjuster

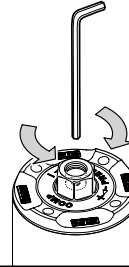

Rebound damping adjuster

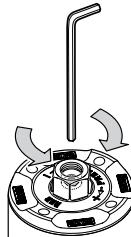

5 CHANGE SPRING AND/OR OIL LEVEL

Warning!

This procedure requires high technical knowledge and/or experience of working with front forks. Contact an Öhlins dealer for advice. See the Vehicle Service Manual.

Caution!

Work with only one fork leg at a time. Do not mix the parts.

1
Release the spring preload fully (counter clockwise).

2
Loosen the upper triple clamp by loosening the screws. Loosen the top cap ½ turn, do not remove it, use tool (00797-08).

3
Remove the front fork from the vehicle according to the vehicle service manual.

4
Loosen the top cap from the outer tube, use tool (00797-08).

5
Use a 19 and a 14 mm wrench to loosen the top cap and remove it from the shaft extension.

6
Remove the spring support, guide sleeve and spring.

7
Measure the oil level and adjust if necessary. See chapter 2.2.

8
See the Spring recommendation in the Mounting Instructions or contact an Öhlins dealer for correct spring. Install Pull up tool (01765-04) on top of the shaft extension. Install the spring, with the marking up, over the tool.

9
Install the guide sleeve and spring support over the tool.

10
Pull up the shaft assembly and grab the spring support with a 19 mm wrench.

11
Make sure that the compression/rebound adjusters are fully open. Remove the Pull-up tool (01765-04) and mount the top cap on the shaft extension. Use a 14 mm socket wrench. Tightening torque 30 Nm.

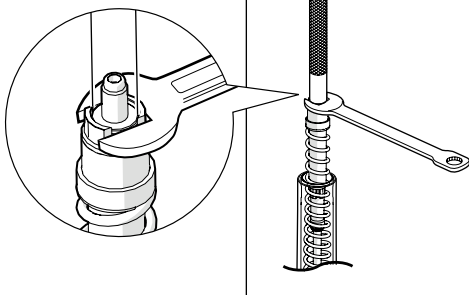
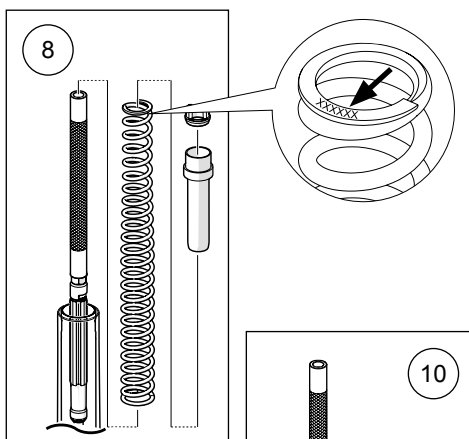
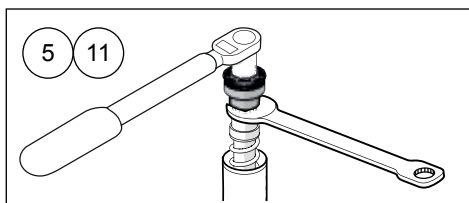
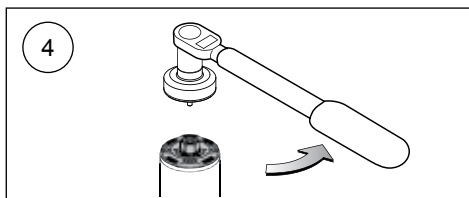
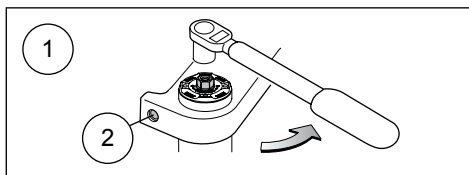

5 CHANGE SPRING AND/OR OIL LEVEL

12

Make sure the fork leg is in a fully extended position. Use Sleeve pin tool (00797-08) to tighten the top cap to the outer tube. Tightening torque 10 Nm.

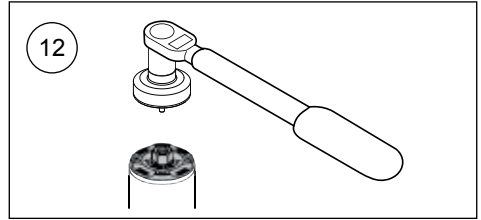

13

Set the compression, rebound and spring preload adjusters according to the Setup Data in the Mounting Instructions.

14

Install the front fork legs into the triple clamps at the recommended Fork leg position according to Setup data in the Mounting instructions. Tightening torque according to vehicle service manual.

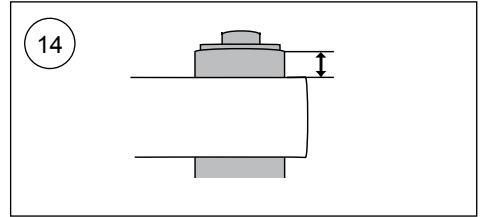

Note!

Measure the fork leg position from the upper triple clamp to the top of the outer tube.

15

Reinstall all removed parts in the same way as they were before the installation. See the vehicle service manual for correct procedure and torque specifications.

6 INSPECTION AND MAINTENANCE

Preventive maintenance and regular inspection reduces the risk of poor performance. If there is any need for additional service, please contact an Öhlins dealer.

Caution!

Never use strong detergents that can damage the surfaces of the front fork. Thinner and brake cleaner will dry out seals, increase the risk of friction, oil leakage or even poor function.

Caution!

Always use Öhlins High Performance Front Fork fluid (01309--).

Inspection points

1. Check the front fork for external oil leakage.
2. Check the inner fork leg for scratches, dents or other defects that may damage the seal/bushing.
3. Check the fender brackets and brake calliper attachments.
4. Check the front fork attachments to the vehicle.

Inspection Intervals

Normal use: Once a year or every 5000km
Race track: Every 10 hours

Once every 2nd year (or 20 000km)

1. Change front fork fluid.
2. Remove the outer fork leg and inspect the bushings, seals and the full length of the inner fork leg.
3. Check and replace seals and bushings if necessary.

Note!

Discarded Öhlins products should be handed over to an Öhlins dealer for proper disposal.

Your Öhlins retailer:

Öhlins Racing AB
Box 722
SE-194 27, Upplands Väsby
Sweden

Phone: +46 (0)8 590 025 00
Fax: +46 (0)8 590 025 80
www.ohlins.com

