



YOSHIMURA

RESEARCH&DEVELOPMENT OF AMERICA, INC.

5420 DANIELS STREET SUITE A, CHINO, CA 91710 · (800) 634-9166 · (909) 628-4722 · FAX (909) 591-2198

www.yoshimura-rd.com

SA-21-K YOSHIMURA TEC-SD24 SPARK ARRESTOR KIT

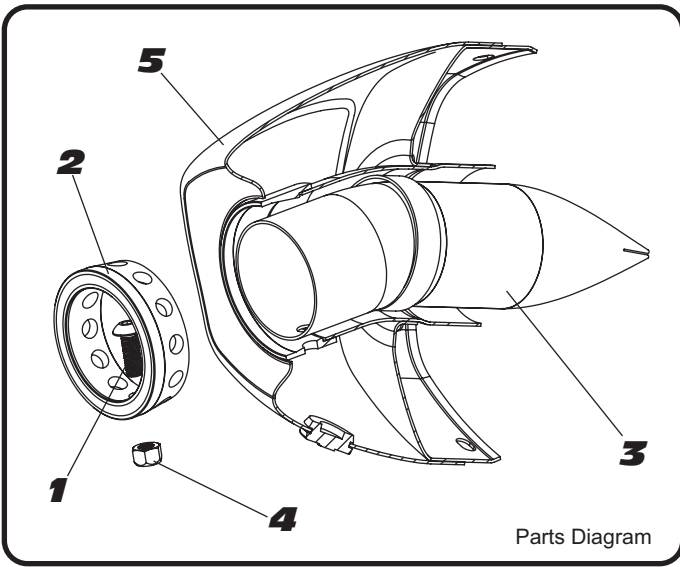

NO.	DESCRIPTION	QTY	PART #
1	5mm X 14mm Button Head Cap Screw	1	M5X14BHS
2	RS-12 Spark Arrestor Ring 1.500"	1	YM1-RING-1500
3	TEC-SD24 Spark Arrestor	1	TEC-SD24
4	5mm Lock Nut	1	5MMLN-U
5	Yoshimura Exhaust	**	**
**	USFS Label	1	17082

- 1 Remove button head screw securing the aluminum ring and spark arrester to the muffler and remove spark arrester.
- 2 Using a wire brush, remove carbon deposits from spark arrester screen. Inspect the screen for excessive wear or damage. If spark arrester is excessively worn or damaged, the spark arrester must be replaced. Cleaning and inspection should be performed after every 60 hours of use.
Caution: Gloves and safety glasses should be worn while cleaning spark arrester.
- 3 Re-install spark arrester and aluminum ring.
Note: It is recommended that a low strength "Loc-tite" is used on the spark arrester securing bolt.
- 4 Apply USFS certified spark arrester label on muffler where visible.



YOSHIMURA

RESEARCH&DEVELOPMENT OF AMERICA, INC.

5420 DANIELS STREET SUITE A, CHINO, CA 91710 · (800) 634-9166 · (909) 628-4722 · FAX (909) 591-2198

www.yoshimura-rd.com

SA-21-K YOSHIMURA TEC-SD24 SPARK ARRESTOR KIT

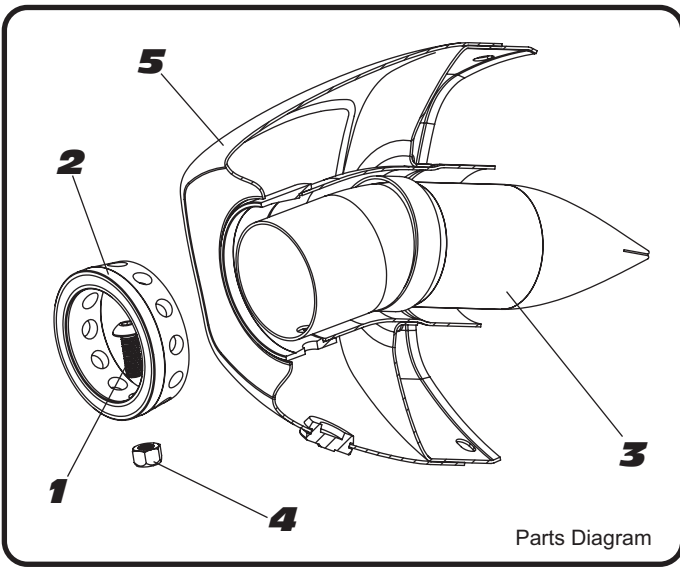

NO.	DESCRIPTION	QTY	PART #
1	5mm X 14mm Button Head Cap Screw	1	M5X14BHS
2	RS-12 Spark Arrestor Ring 1.500"	1	YM1-RING-1500
3	TEC-SD24 Spark Arrestor	1	TEC-SD24
4	5mm Lock Nut	1	5MMLN-U
5	Yoshimura Exhaust	**	**
**	USFS Label	1	17082

- 1 Remove button head screw securing the aluminum ring and spark arrester to the muffler and remove spark arrester.
- 2 Using a wire brush, remove carbon deposits from spark arrester screen. Inspect the screen for excessive wear or damage. If spark arrester is excessively worn or damaged, the spark arrester must be replaced. Cleaning and inspection should be performed after every 60 hours of use.
Caution: Gloves and safety glasses should be worn while cleaning spark arrester.
- 3 Re-install spark arrester and aluminum ring.
Note: It is recommended that a low strength "Loc-tite" is used on the spark arrester securing bolt.
- 4 Apply USFS certified spark arrester label on muffler where visible.