



# YOSHIMURA

RESEARCH&DEVELOPMENT OF AMERICA, INC.

5420 DANIELS STREET STE A, CHINO CA., 91710 · (800) 634-9166 · (909) 628-4722 · FAX (909) 591-2198

[www.yoshimura-rd.com](http://www.yoshimura-rd.com)

## *Signature Series*

Qualified Manufacturer Declared "Replacement Part"

**2012~2018**

**Yamaha Super Tenere  
13120HD520 (SS/CF)**

**Works Finish  
RS-4 Stainless Steel Slip-On**

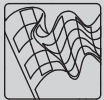

Signature Series systems are:

- CARB/EPA tail-pipe emissions compliant.
- Marked with appropriate EPA noise labels.
- Independent laboratory tested for EPA new vehicle noise compliance.



*You must know how to remove and replace your stock exhaust in order to install this product otherwise have it installed by a professional mechanic. Keep all stock parts from your existing system as some components may be necessary to install your new Yoshimura exhaust depending on the application. Read through all instructions before beginning installation. Exhaust system can be extremely hot. Let motorcycle cool down before beginning installation. Always wear hand and eye protection and take precautionary measures to avoid injury.*



NOTE: IN THE STATE OF CALIFORNIA, IT IS ILLEGAL TO MODIFY THE EMISSION CONTROL SYSTEM, WHICH INCLUDES THE CARBURETORS OF ANY VEHICLE.

## Assembly Diagram

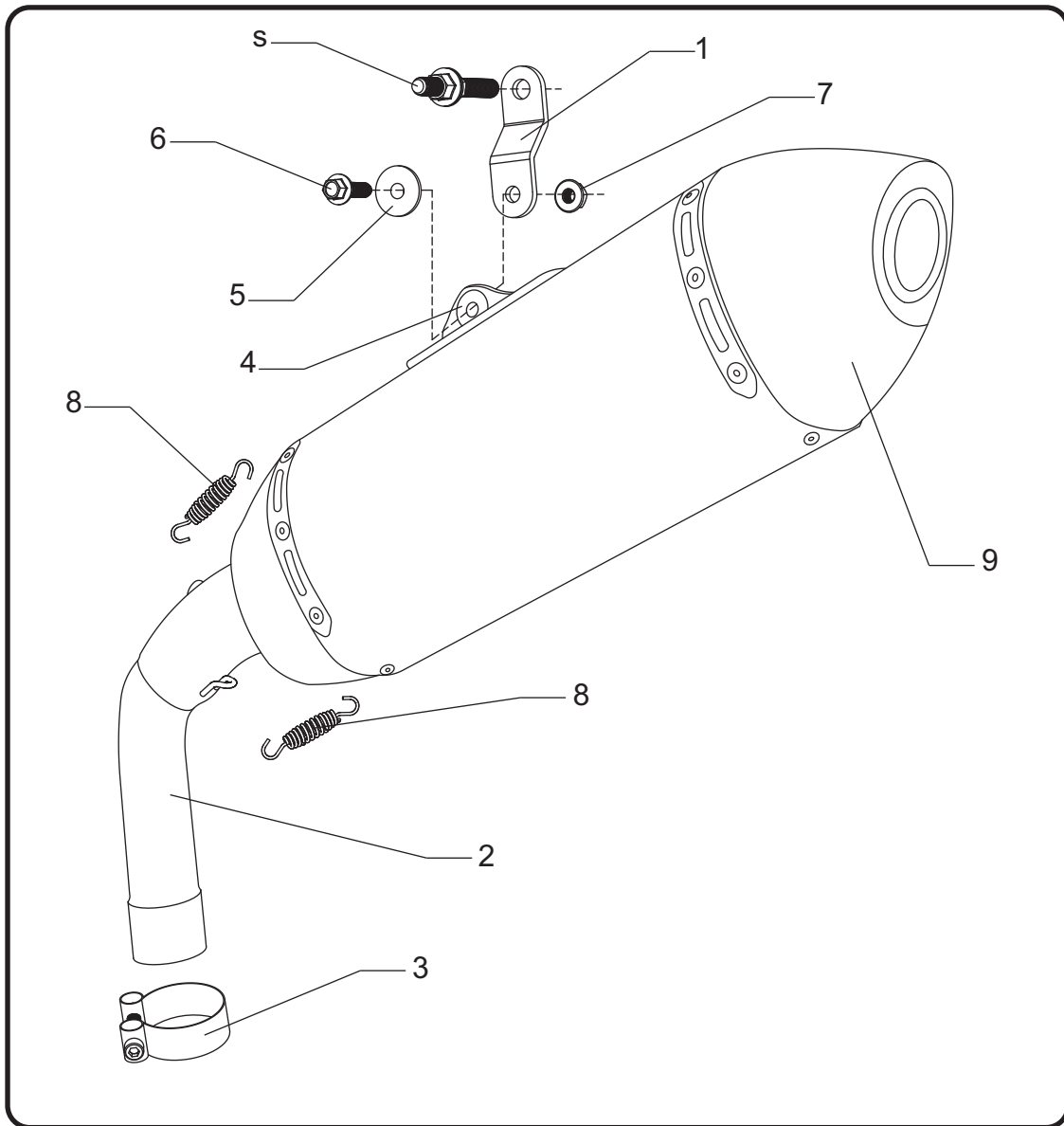

No.	Item	Description	Qty.
1	13120-BRKT	Yoshimura Muffler Hanger Bracket	1
2	13120-435D	Yoshimura Tailpipe	1
3	27-61M	Exhaust Clamp	1
4	Z1022	Rubber Grommet	1
5	ALS-003	Aluminum Spacer	1
6	M8X30H	8mmx 30mm Flanged Hex Head Bolt	1
7	8MMNUT	8mm Flange Nut	1
8	RACE-SPS-1	Medium Exhaust Spring	2
9	****	Signature Series Muffler	1
**	ST-200	Spring Puller Tool	1
**	347PLUG	Muffler Wash Plug	1
**	17029	Sticker Kit Sheet	1

\*\*\*\* Signature Series muffler replacement part number unavailable. Repair or replacement of Signature Series exhaust systems is only available directly through Yoshimura R&D of America, Inc.

## Removal

1. Remove the muffler heatshield by removing the one nut and two bolts.
2. Loosen the stock exhaust clamp at tailpipe and header connection.
3. While securely supporting the muffler, remove the muffler mount bolt.
4. Carefully remove the muffler assembly from the stock header.

Note: The stock exhaust gasket will not be used with the Yoshimura Signature Series exhaust system.

## Installation

1. Install (No. 1) *13120-BRKT*, muffler hanger bracket using the stock muffler mounting hardware. Orientation is as follows: Stock muffler mount bolt, muffler hanger bracket, stock spacer, stock rubber bushing, stock washer, and stock nut. Do not torque at this time.

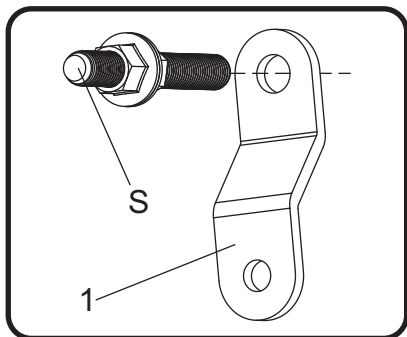

2. Slide (No. 3) *27-61M*, exhaust clamp over (No. 2) *13120-435D*, Yoshimura tailpipe inlet.

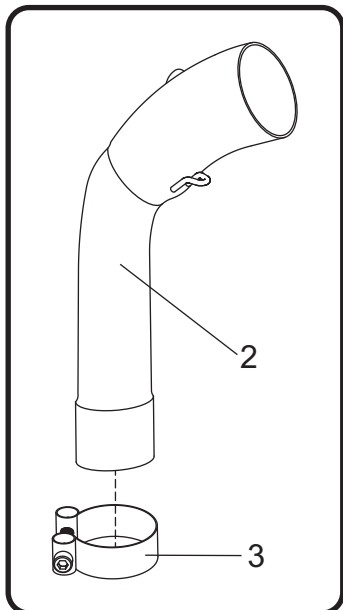

3. Install (No. 4) *Z1022*, rubber grommets into muffler brackets.

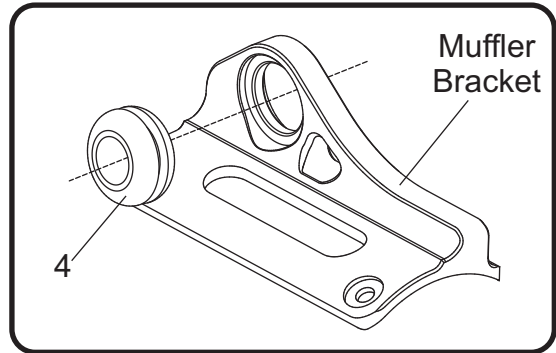

4. Carefully slide Yoshimura muffler assembly over the stock header outlet. Secure muffler to (No. 1) *13120-BRKT*, muffler hanger bracket using the hardware provided in the kit. Orientation is as follows: (No. 6) *M8X30H*, 8mm bolt, (No. 5) *ALS-003*, aluminum spacer, (No. 9) *muffler*, (No. 1) *13120-BRKT*, muffler hanger bracket, and (No. 7) *8MMNUT*, flange nut. See diagram below.

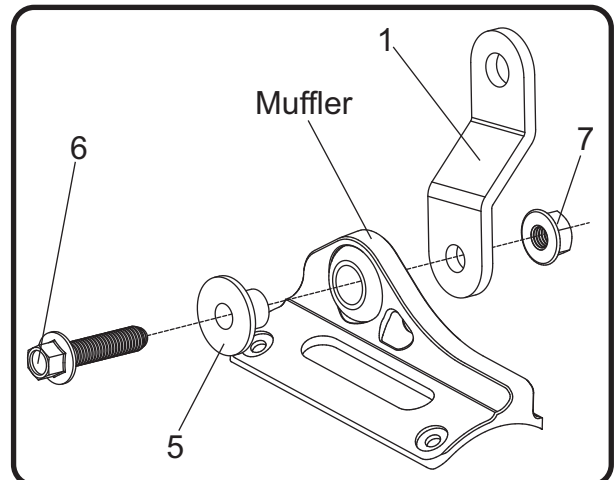

5. Torque (No. 6) *M8X30H*, muffler mount bolt to 30 Nm (3.0 kg-m, 22 ft-lb). Torque (No. 3) *27-61M* exhaust clamp to 20 Nm (2.0 kg-m, 14 ft-lb). Torque the stock muffler hanger bracket bolt to 47 Nm (2.7 kg-m, 34 ft-lb).
6. Re-install muffler heatshield using the reverse steps of removal.
7. Before starting motorcycle, check for proper clearance between new exhaust system and rear suspension (i.e. tire, swing arm, brakes, rear shock, and etc.) If any problem is found, please carefully follow through the installation steps again. If problem still persists, please call Yoshimura Tech Department at (800) 634-9166 / in CA (909) 628-4722.

8. It is recommended that the muffler and tailpipe be wiped down with rubbing alcohol to remove oil and fingerprints. This will help prevent tarnishing of the finish after the exhaust is heated up.

Note: After starting motorcycle, it is normal for new exhaust system and muffler to emit smoke until oil residue burns off.

## **Works Finish Care & Maintenance**

---

Before starting vehicle, clean pipe thoroughly using a soft cloth and rubbing alcohol to remove any oil and finger prints.

The color of the exhaust will change once the system has gone through a heat cycle of 15 minutes or more. Color will vary depending on lean/rich conditions.

Clean using a soft cloth and soap. Do not use abrasive materials as it will scratch the surface.

Surface reconditioning services are available to remove scratches and undesirable discoloration due to extreme heat. Contact Yoshimura Tech Department at (800) 634-9166 / in CA (909) 628-4722 for more information.

## **NOISE EMISSION WARRANTY**

Yoshimura warrants that this exhaust system, at time of sale, meets all applicable U.S. E.P.A. Federal noise standards. This warranty extends to the first person who buys this exhaust system for purposes other than resale, and to all subsequent buyers. Warranty claims should be directed to Yoshimura R&D of America, Inc. 5420 Daniels St. Chino, CA 91710 | Tel (800) 634-9166

## **TAMPERING PROHIBITION**

Federal law prohibits any modification to this exhaust system which causes the motorcycle to exceed the Federal noise standard. Use of the motorcycle with such a modified exhaust system is also prohibited.

Acts likely to constitute tampering include removal or puncturing the muffler, baffles, header pipes, or any other component which conducts exhaust gases.

**WARNING: This product should be checked for repair or replacement if the motorcycle noise has increased significantly through use. Otherwise, the owner may become subject to penalties under state and local ordinances.**