



YOSHIMURA

RESEARCH & DEVELOPMENT OF AMERICA, INC.

5420 DANIELS STREET STE A, CHINO CA 91710 · (800) 634-9166 · (909) 628-4722 · FAX (909) 591-2198

WWW.YOSHIMURA-RD.COM

Signature Series

Qualified Manufacturer Declared "Replacement Part"

2015~2016
Honda CRF450R
225821H220 (CF/CF)
225821H720 (Ti/CF)
RS-9 Titanium Full-System

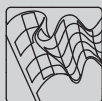

Signature Series systems are:

- CARB/EPA tail-pipe emissions compliant.
- Marked with appropriate EPA noise labels.
- Independent laboratory tested for EPA new vehicle noise compliance.

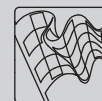

CAUTION: The muffler packing on this system **MUST** be replaced every 6-8 hours of use, or every 1-2 motos. Failure to follow recommended muffler re-packing interval can cause muffler damage and may void the warranty.



NOTE: IN THE STATE OF CALIFORNIA, IT IS ILLEGAL TO MODIFY THE EMISSION CONTROL SYSTEM, WHICH INCLUDES THE FUEL INJECTION OF ANY VEHICLE.

Assembly Diagram

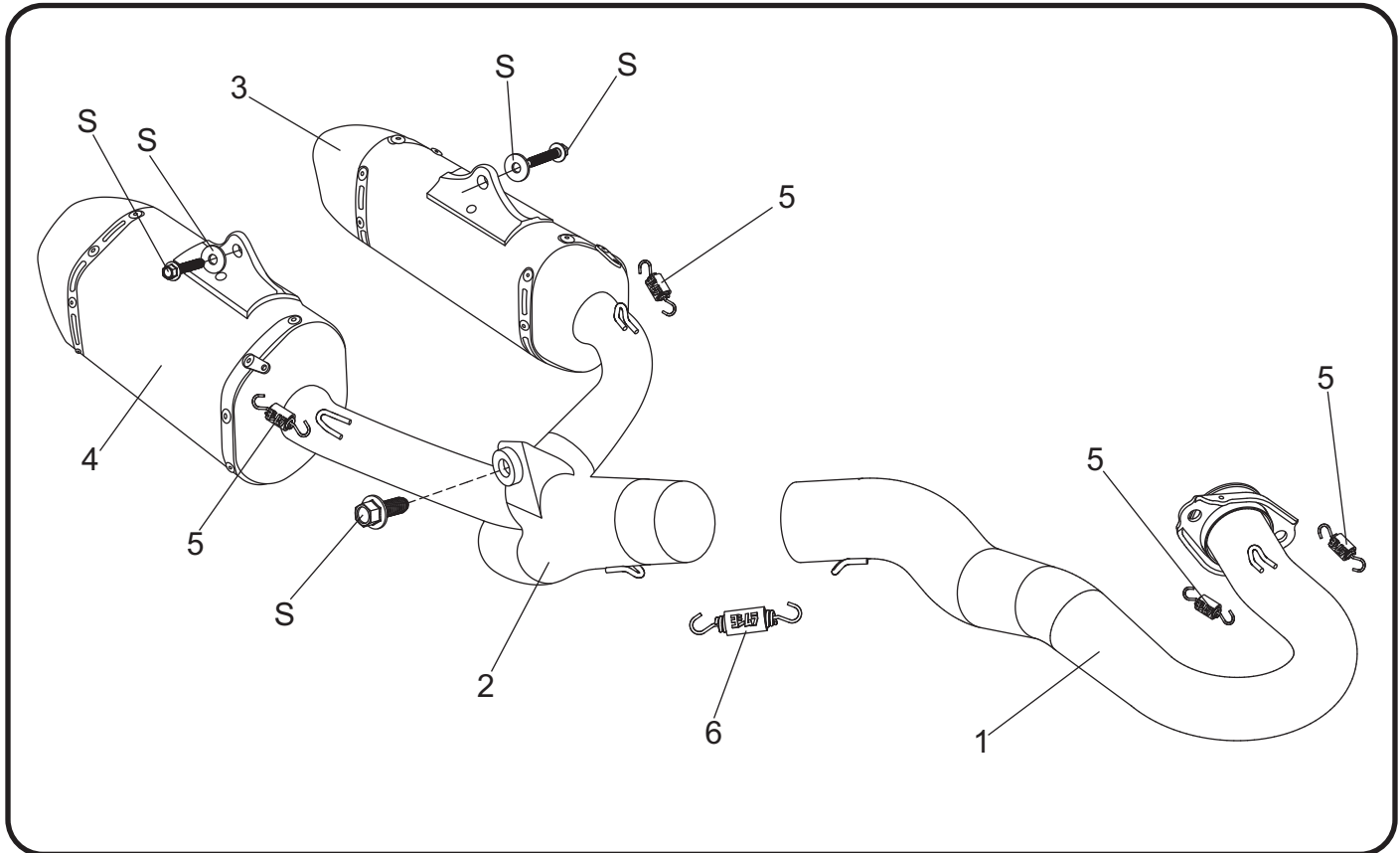

No.	Item	Description	Qty.
1	22582-704F	Yoshimura Titanium Header Kit	1
2	22581-744	Yoshimura Titanium Tailpipe	1
3	****	Signature Series Left Muffler	1
4	****	Signature Series Right Muffler	1
5	RACE-SPX-1	Small Exhaust Spring	4
6	RACE-SPS-1	Medium Exhaust Spring	1
**	05747076	3mm Hex Key	1
**	ST-200	Spring Puller Tool	1
**	17029	Sticker Kit Sheet	1

** Not shown in diagram.

**** Signature Series muffler replacement part number unavailable. Repair or replacement of Signature Series exhaust systems is only available directly through Yoshimura R&D of America, Inc.

Removal

1. Remove the left and right number plate.
2. Remove the right side airbox cover.
3. Remove the rear mud guard.
4. Loosen the right side muffler exhaust clamp.
5. While securely supporting the right muffler assembly, remove the right muffler mount bolt and carefully remove right side muffler by sliding toward the rear of motorcycle.
6. Loosen the exhaust clamp at header and tailpipe connection.
7. Loosen the header nuts for adjustability.
8. Remove tailpipe chassis mount bolt securing tailpipe assembly to subframe.

Note: The stock tailpipe chassis mount bolt shim will not be used with the Yoshimura full-system exhaust.

9. While securely supporting the left muffler assembly, remove the left side muffler mount bolt and carefully remove left side muffler and tailpipe assembly by sliding off of the stock header toward the rear of motorcycle.
10. Remove header nuts and carefully remove the stock header.

Note: The stock exhaust port gasket will be re-used with the Yoshimura full-system exhaust. Inspect and replace if necessary.

Installation

1. Install (No. 1) 22582-704F, Yoshimura header using the stock header nuts. Do not torque at this time.

Note: For ease of installation, install (No. 5) RACE-SPX-1, small exhaust springs onto flange before installing.

2. Carefully install (No. 2) 22581-744, Yoshimura midpipe by sliding onto header outlet.

3. Using the stock tailpipe chassis mount bolt, secure (No. 2) 22581-744, Yoshimura tailpipe to subframe. Do not torque at this time.

Note: Start threads by hand to prevent cross-threading.

4. Install Yoshimura left and right muffler assembly onto (No. 2) 22581-744, Yoshimura tailpipe outlets.
5. Secure left and right muffler to subframe using the stock muffler mount washer and bolt.
6. Torque muffler mount bolt to factory specification.
7. Torque tailpipe chassis mount bolt to factory specification.
8. Torque header nuts to factory specification.
9. Using the ST-200, spring puller tool provided in the kit, install (No. 5) RACE-SPX-1, small exhaust springs onto left and right muffler and tailpipe connection.

Note: Hook spring onto muffler spring tab from the inside out to prevent the end of the spring from contacting the front cap of the muffler.

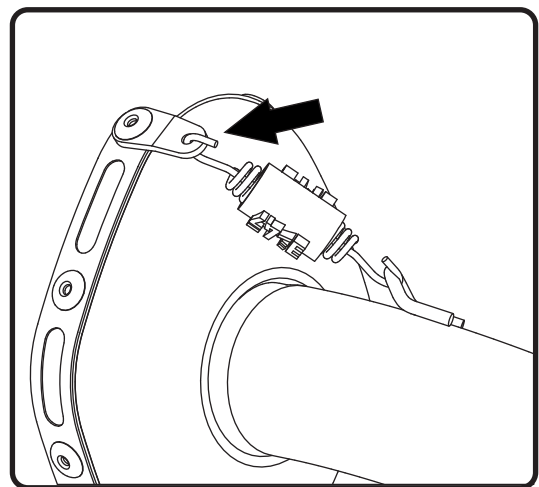

10. Install (No. 5) RACE-SPX-1, small exhaust spring onto flange and header connection.
11. Install (No. 6) RACE-SPS-1, medium exhaust spring between header and tailpipe connection.
12. Re-install right side airbox cover.

13. Re-install left and right side number plate.

Note: It is recommended to secure the two rubber side panel bumpers using an appropriate adhesive (ie. glue, epoxy, rubber cement, or etc.). Failure to secure rubber bumpers may cause the plastic side panel to directly contact the muffler body and can cause muffler to fail. This type of muffler failure is not eligible for warranty claim. Periodically verify that the rubber bumpers are secure prior to riding.

14. Re-install mud guard.

15. Before starting motorcycle, check for proper clearance between new exhaust system and rear suspension (i.e. tire, swingarm, brakes, rear shock, and etc.) If any problem is found, please carefully follow through the installation steps again. If problem still persists, please call Yoshimura Tech Department at (800) 634-9166 / in CA (909) 628-4722.

16. It is recommended that the muffler and tailpipe be wiped down with rubbing alcohol to remove oil and fingerprints. This will help prevent tarnishing of the finish after the exhaust is heated up.

Note: After starting motorcycle, it is normal for new exhaust system and muffler to emit smoke until oil residue burns off.