

# YOSHIMURA

RESEARCH & DEVELOPMENT OF AMERICA, INC.

5420 DANIELS STREET STE A, CHINO CA 91710 · (800) 634-9166 · (909) 628-4722 · FAX (909) 591-2198

WWW.YOSHIMURA-RD.COM

## *Signature Series*

Qualified Manufacturer Declared "Replacement Part"

**2017 ~ 2018**

**Kawasaki KX250F**

**242932D320 (SS/AL)**

**RS-4 Stainless Steel Slip-On**

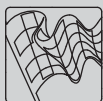

Signature Series systems are:

- CARB/EPA tail-pipe emissions compliant.
- Marked with appropriate EPA noise labels.
- Independent laboratory tested for EPA new vehicle noise compliance.

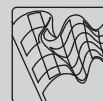

CAUTION: The muffler packing on this system **MUST** be replaced every 6-8 hours of use, or every 1-2 motos. Failure to follow recommended muffler re-packing interval can cause muffler damage and may void the warranty.



NOTE: IN THE STATE OF CALIFORNIA, IT IS ILLEGAL TO MODIFY THE EMISSION CONTROL SYSTEM, WHICH INCLUDES THE FUEL INJECTION OF ANY VEHICLE.

**Caution:** Exhaust system can be extremely hot. Let motorcycle cool down before beginning installation. Always wear hand and eye protection and take precautionary measures to avoid injury.

**Note:** Read through all instructions before beginning installation.

## Tools Needed:

- Metric Socket Set
- Ratchet Wrench and Extension
- Torque Wrench
- Spring Puller Tool

## Installation Steps:

1. Remove stock exhaust system.
  - a. Remove right rear number plate (see Fig. 1).
  - b. Loosen exhaust clamp and slide forward onto header (see Fig. 2).
  - c. Remove muffler mounting bolts and remove muffler. (See Fig. 2)
  - d. Remove exhaust clamp from header.
  - e. Loosen stock header bolts.
2. Install Yoshimura exhaust system
  - a. Insert rubber grommet into muffler mounting bracket.
  - b. Insert aluminum spacer into rubber grommet.  
*Note: Aluminum spacer is to rest between muffler and subframe. See Fig. 3*
  - c. Slide supplied tailpipe clamp onto stock header in orientation as shown in the parts diagram.
  - d. Insert muffler/tailpipe assembly onto header outlet.  
*Note: Yoshimura system does not retain stock gasket or exhaust clamp.*
  - e. Install Yoshimura Muffler using stock muffler mounting bolt and supplied washer. Orientation is as follows: Bolt, Washer, Rubber Grommet (Inside of muffler bracket), Aluminum Spacer, Subframe. Do not torque at this time.
  - f. Install Yoshimura Tailpipe using stock tailpipe bracket bolt. Do not torque at this time.
  - g. Torque header nuts to 16.5 lb-ft (23 N-m).
  - h. Torque tailpipe mounting bolt to 16.5 lb-ft (23 N-m).
  - i. Torque muffler mounting bolt to 16.5 lb-ft (23 N-m).
  - j. Slide tailpipe clamp over tailpipe to header connection. Torque collector clamp to 7 lb-ft (10 N-m).



Fig. 1



Fig. 2

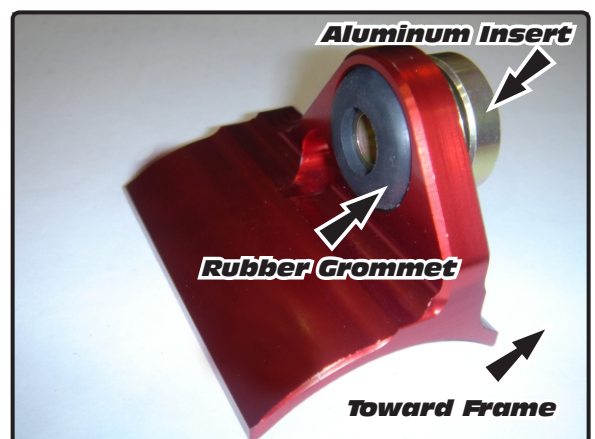
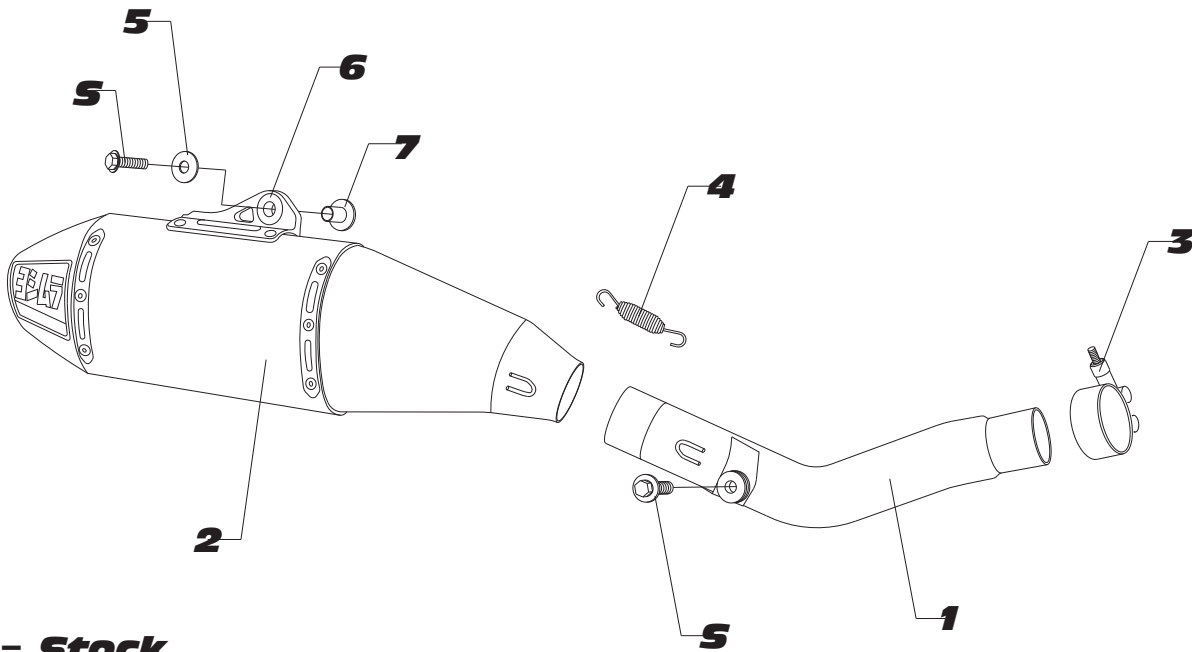

Fig. 3

3. *It is recommended that the muffler and tailpipe be wiped down with rubbing alcohol to remove oil and fingerprints. This will help prevent tarnishing of the finish after the exhaust is heated up.*
4. *Before starting motorcycle, check for proper clearance between new exhaust system and rear suspension (i.e. tire, swingarm, brake, rear shock, etc). If any problem is found, please carefully repeat through the installation steps. If problem still persists, please call Yoshimura tech department at (800) 634-9166 / in CA (909) 628-4722.*
5. *Reinstall number plate using reverse steps of removal. Some trimming of the number plate may be necessary if it is hitting the muffler sleeve.*

**NOTE:** *After starting motorcycle, it is normal for new exhaust system and muffler to emit smoke until oil residue burns off.*

**PN: 242932D320**



Parts Diagram

<b>NO.</b>	<b>DESCRIPTION</b>	<b>QTY</b>	<b>PART #</b>
1	Yoshimura Stainless Steel Tailpipe	1	24293-152
2	Yoshimura RS4 Muffler w/ Aluminum Sleeve	1	242922D320-RMA
3	Stainless Tailpipe Clamp	1	22059
4	Muffler Spring, Medium	1	RACE-SPS-1
5	8mm Flat Washer, Large	1	8MMWASHERL
6	Muffler Bracket Rubber Grommet	1	Z1022
7	Aluminum Insert	1	ALS-002
**	AMA 94dB Sound Insert (Installed)	1	INS-U-3
**	Yoshimura Vinyl Sticker	1	17029
**	Muffler Washer Plug	1	347PLUG
**	Instruction Manual	1	INST KIT
**	Muffler Spring Tool	1	ST-200
<b>OPTIONAL REPLACEMENT PARTS</b>			
****	Spark Arrestor Kit		SA-04-K
****	Re-pack Kit		REPACK-RS4-PK11



# YOSHIMURA

RESEARCH&DEVELOPMENT OF AMERICA, INC.

5420 DANIELS STREET SUITE A, CHINO, CA 91710 · (800)634-9166 · (909)628-4722 · FACSIMILE (909)591-2198

[www.yoshimura-rd.com](http://www.yoshimura-rd.com)

**INS-22-K**

**YOSHIMURA RS4 LOW VOLUME INSERT KIT**

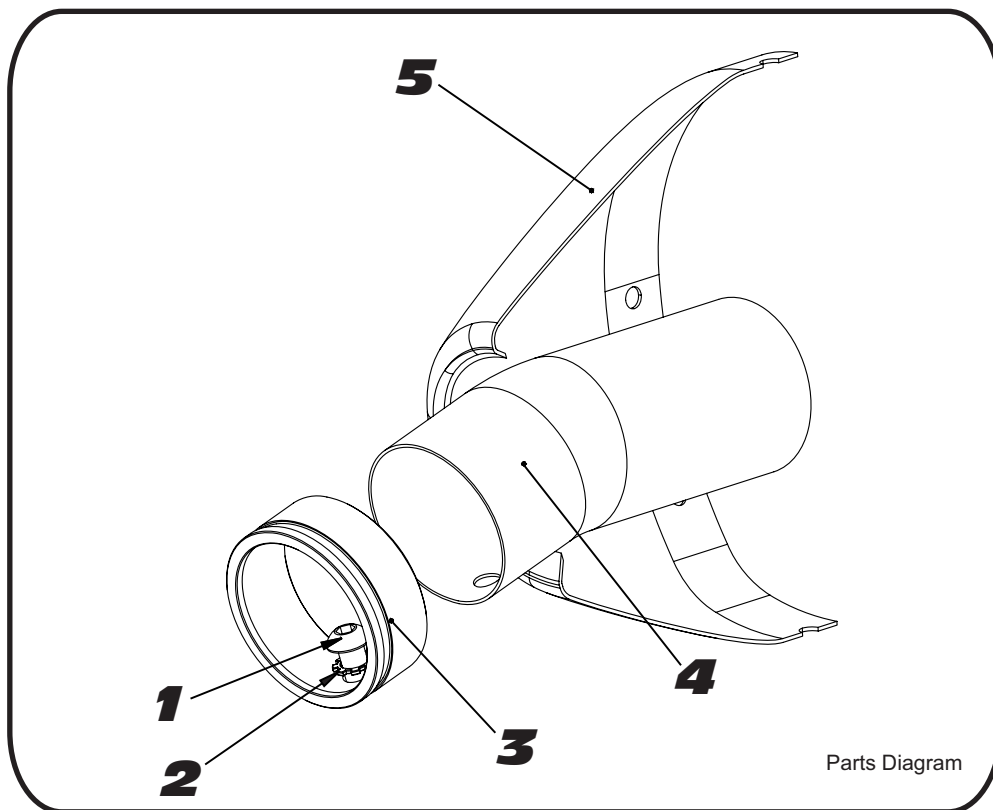

DESCRIPTION	QTY	PART #
6mm X 12mm Button Head Cap Screw	1	M6X12BHS
6mm Lock Washer	1	6MMLCKWSHR-TH
RS4 Aluminum Insert Ring	1	RS4-RING-1500
Low Volume Sound Insert	1	INS-U-3
Yoshimura Exhaust	**	**

- 1 Using a 4mm Allen key, remove the bolt that secures the aluminum ring and sound insert to the muffler (see Parts Diagram for location).
- 2 Remove the sound insert from the muffler.
- 3 Inspect the sound insert for cracks or damage and replace if necessary.
- 4 Re-install sound insert and aluminum ring. Torque the sound insert securing bolt to 1.0 kg-m (7.3 lb-ft).  
**NOTE:** It is recommended that a low strength "Loc-tite" is used on the sound insert securing bolt.