



# YOSHIMURA

RESEARCH&DEVELOPMENT OF AMERICA, INC.

5420 DANIELS STREET STE A, CHINO CA 91710 · (800) 634-9166 · (909) 628-4722 · FAX (909) 591-2198

WWW.YOSHIMURA-RD.COM

Qualified Manufacturer Declared "Replacement Part"

## **SIGNATURE SERIES**

**2016~2017**  
**KTM 250 SX-F**  
**KTM 350 SX-F**

**2016~2017**  
**Husqvarna**  
**FC 250/350**

## **ENDURO SERIES**

**2016~2017**  
**KTM 250 XC-F**  
**KTM 350 XC-F**

**262522D321 (SS/AL)**  
**Stainless Steel RS-4 Slip-On**

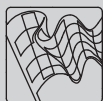

Signature Series systems are:

- CARB/EPA tail-pipe emissions compliant.
- Marked with appropriate EPA noise labels.
- Independent laboratory tested for EPA new vehicle noise compliance.

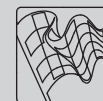

❖ CAUTION: The muffler packing on this system **MUST** be replaced every 6-8 hours of use, or after each moto. Failure to follow recommended muffler re-packing interval can cause muffler damage and may void the warranty. ❖

NOTE: IN THE STATE OF CALIFORNIA, IT IS ILLEGAL TO MODIFY THE EMISSION CONTROL SYSTEM, WHICH INCLUDES THE CARBURETORS OF ANY VEHICLE.

## Assembly Diagram

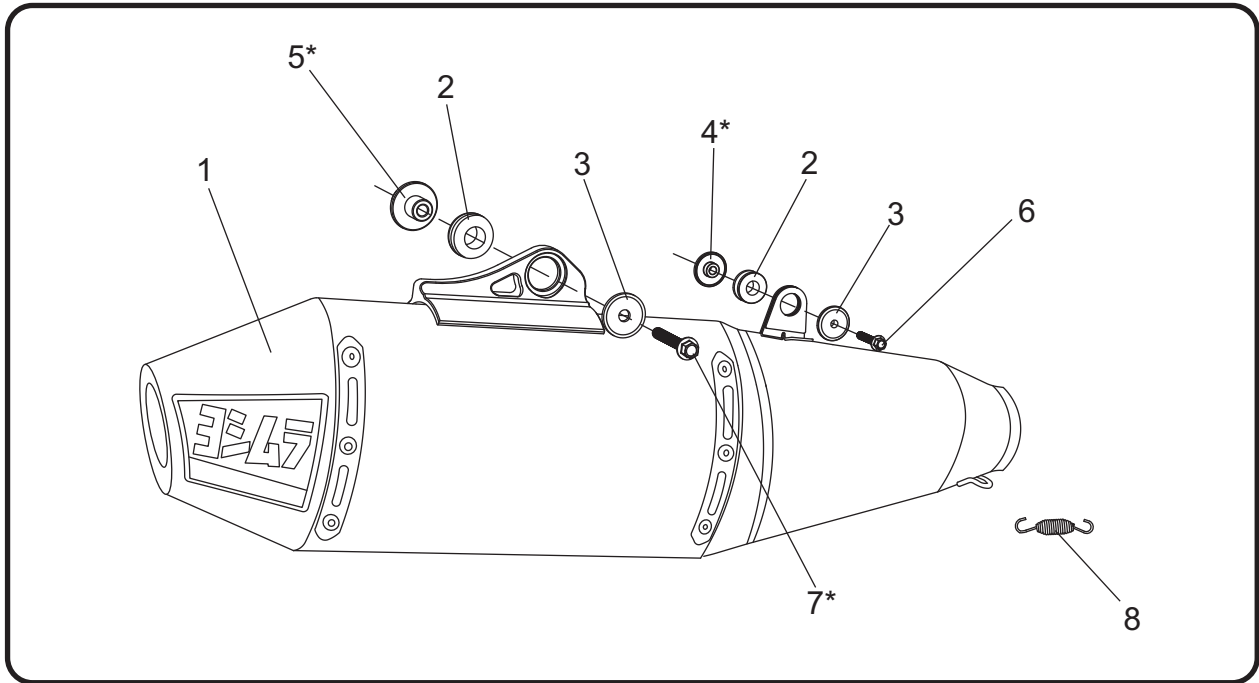

No.	Item	Description	Qty.
1	262520D321-RMA	Yoshimura Muffler Assembly	1
2	Z1023	Rubber Grommet	2
3	ALS-046	Aluminum Spacer	2
4*	ALS-054	Aluminum Spacer for Husqvarna	1
	ALS057	Aluminum Spacer for KTM	1
5*	ALS-047	Aluminum Spacer for Husqvarna	1
	ALS-056	Aluminum Spacer for KTM	1
6	M6X35H	6mm x 35mm Flanged Hex Head Bolt	1
7*	M6X45H	6mm x 45mm Flanged Hex Head Bolt	1
	M6X50H	6mm x 50mm Flanged Hex Head Bolt	1
8	RACE-SPS-1	Medium Exhaust Spring	1
**	INS-U-2	Low Volume Sound Insert (Installed)	1
**	ST-200	Spring Puller Tool	1
**	347PLUG	Wash Plug	1
**	17029	Sticker Sheet	1
**	INS-24-K	Low Volume Sound Insert Kit	1
<b>OPTIONAL REPLACEMENT PARTS</b>			
REPACK-RS4-PK12		Re-pack Kit	

\*\* Not shown on diagram.

**CAUTION:** Exhaust system can be extremely hot. Let motorcycle cool down before beginning installation. Always wear hand and eye protection and take precautionary measures to avoid injury.

**WARNING:** Always properly support vehicle with a stand and/or lift when servicing or performing any work. Unstable vehicles may present dangerous conditions and may cause property damage and/or personal injury.

**NOTE:** Read through all instructions before beginning installation.

## Removal

1. Remove right side panel to access the muffler mount bolts.
2. Remove the stock exhaust spring between the muffler and header.
3. While securely supporting the stock muffler, remove the two muffler mount bolts and carefully remove the stock muffler by sliding toward the rear.

## Installation

1. Install (No. 2) Z1023, rubber grommet into muffler resonator bracket.

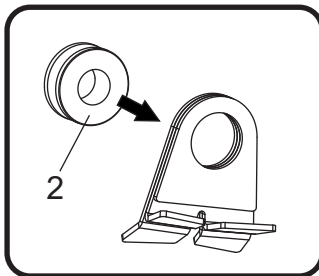

2. Install (No. 3) ALS-046, aluminum spacer in the front side of (No. 2) Z1023, rubber grommet and install (No. 4) ALS-054, for Husqvarna OR ALS-057 for KTM aluminum spacer in the back side of (No. 2) Z1023, rubber grommet as shown below.

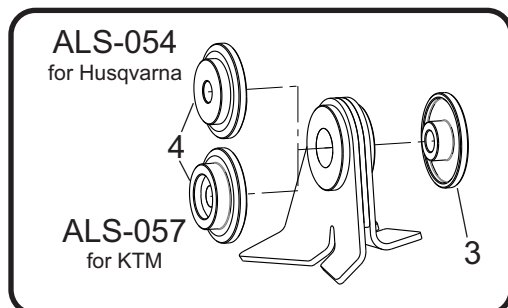

3. Install (No. 2) Z1023, rubber grommet into muffler bracket.

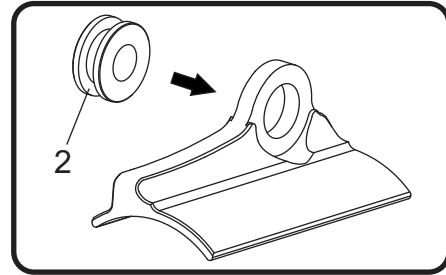

4. Install (No. 5) ALS-047 for Husqvarna OR ALS-056 for KTM, aluminum spacer in the backside of (No. 2) Z1023, rubber grommet and install (No. 3) ALS-046, aluminum spacer in the frontside as shown below.

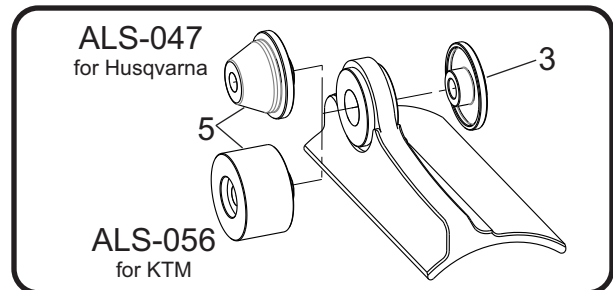

5. Install (No. 1) muffler, onto the stock header outlet. Align muffler bracket and muffler resonator bracket to subframe and secure using (No. 6,7\*) 6mm bolts as shown in the assembly diagram.

Note<sup>1</sup>: For KTM rear muffler mount bolt, use M6X45H.  
For Husqvarna rear muffler mount bolt, use M6X50H.

Note<sup>2</sup>: It is recommended to trim the tab on the bottom right side cover near the header outlet.



6. Torque muffler mount bolts to factory specification.

7. Install (No. 8) *RACE-SPS-1*, medium exhaust spring between Yoshimura muffler and stock header.
8. Re-install right side cover.
9. Before starting vehicle, check for proper clearance between new exhaust system and rear suspension (i.e. tire, swingarm, brakes, rear shock, and etc.) If any problem is found, please carefully follow through the installation steps again. If problem still persists, please call Yoshimura Tech Department at (800) 634-9166 / in CA (909) 628-4722.
10. It is recommended that the muffler and tailpipe be wiped down with rubbing alcohol to remove oil and fingerprints. This will help prevent tarnishing of the finish after the exhaust is heated up.

Note: After starting motorcycle, it is normal for new exhaust system and muffler to emit smoke until oil residue burns off.