



YOSHIMURA

RESEARCH&DEVELOPMENT OF AMERICA, INC.

5420 DANIELS STREET STE A, CHINO CA 91710 · (800)634-9166 · (909)628-4722 · FACSIMILE (909)591-2198

WWW.YOSHIMURA-RD.COM

SIGNATURE SERIES

ENDURO SERIES

Qualified Manufacturer Declared "Replacement Part"

KTM

2011~2015 250 SX-F
2011~2015 350 SX-F
2011~2015 450 SX-F

KTM

2014~2015 350 EXC-F
2012~2015 450 XC-W
2013~2015 450 XC-F
2012~2015 500 EXC
2012~2015 500 XC-W

263502D321 (AL/CF) RS-4 Stainless Steel Slip-On



Signature Series systems are:

- CARB/EPA tail-pipe emissions compliant.
- Marked with appropriate EPA noise labels.
- Independent laboratory tested for EPA new vehicle noise compliance.



Enduro Series systems are:

- Equipped with USFS-approved spark arrestor.
- CARB/EPA tail-pipe emissions compliant.
- All applications are marked with appropriate EPA noise labels.
- Have not been tested for EPA new vehicle noise compliance.



CAUTION: The muffler packing on this system **MUST** be replaced every 6-8 hours of use, or after each moto. Failure to follow recommended muffler re-packing interval can cause muffler damage and may void the warranty.



NOTE: IN THE STATE OF CALIFORNIA, IT IS ILLEGAL TO MODIFY THE EMISSION CONTROL SYSTEM, WHICH INCLUDES THE CARBURETORS OF ANY VEHICLE.

CAUTION: Exhaust system can be extremely hot. Let motorcycle cool down before beginning installation. Always wear hand and eye protection and take precautionary measures to avoid injury.

WARNING: Always properly support vehicle with a stand and/or lift when servicing or performing any work. Unstable vehicles may present dangerous conditions and may cause property damage, personal injury and/or death.

Note: Read through all instructions before beginning installation.

Tools Needed:

Metric Socket Set
Ratchet Wrench and Extension
Torque Wrench
Spring Puller Tool

IMPORTANT NOTE

Signature Series Applications:

The Yoshimura Slip-On exhaust system comes pre-installed with the 450SX-F AMA 94 dB Sound Insert. Inserts for the 250SX-F and 350SX-F is available for additional cost.

See parts diagram list and optional parts list for more information. Check with your local racing organization for sound specification.

Enduro Series Applications:

The supplied spark arrestor and USFS decal MUST be installed on muffler before operating vehicle in order for legal use on public lands.

Spark arrestor is USFS approved and 96dB or lower compliant.

License plate and turn signals must be relocated for EXC models.

Installation Steps:

1. Stock exhaust removal.

- Follow owner's manual instructions to remove stock silencer.
- Loosen tailpipe mount.

2. Yoshimura slip-on installation.

- Install Yoshimura muffler onto stock tailpipe and secure using included hardware. Do not tighten bolts or install springs at this time.
- Tighten muffler mounts to 7.4 ft-lbs (10 N-m).
- Install supplied spring between stock tailpipe and Yoshimura muffler. Tighten tailpipe mount

3. Before starting motorcycle, check for proper clearance between new exhaust system and rear suspension (i.e. tire, swing-arm, brake, rear shock, engine etc). If any problem is found, please carefully follow through the installation steps again. If problem still persists, please call Yoshimura Tech Department at (800) 634-9166 / in CA (909) 628-4722.

It is recommended that the muffler and tailpipe be wiped down with rubbing alcohol to remove oil and fingerprints. This will help prevent tarnishing of the finish after the exhaust is heated up.

NOTE: After starting motorcycle, it is normal for new exhaust system and muffler to emit smoke until oil residue burns off.

#263502D321

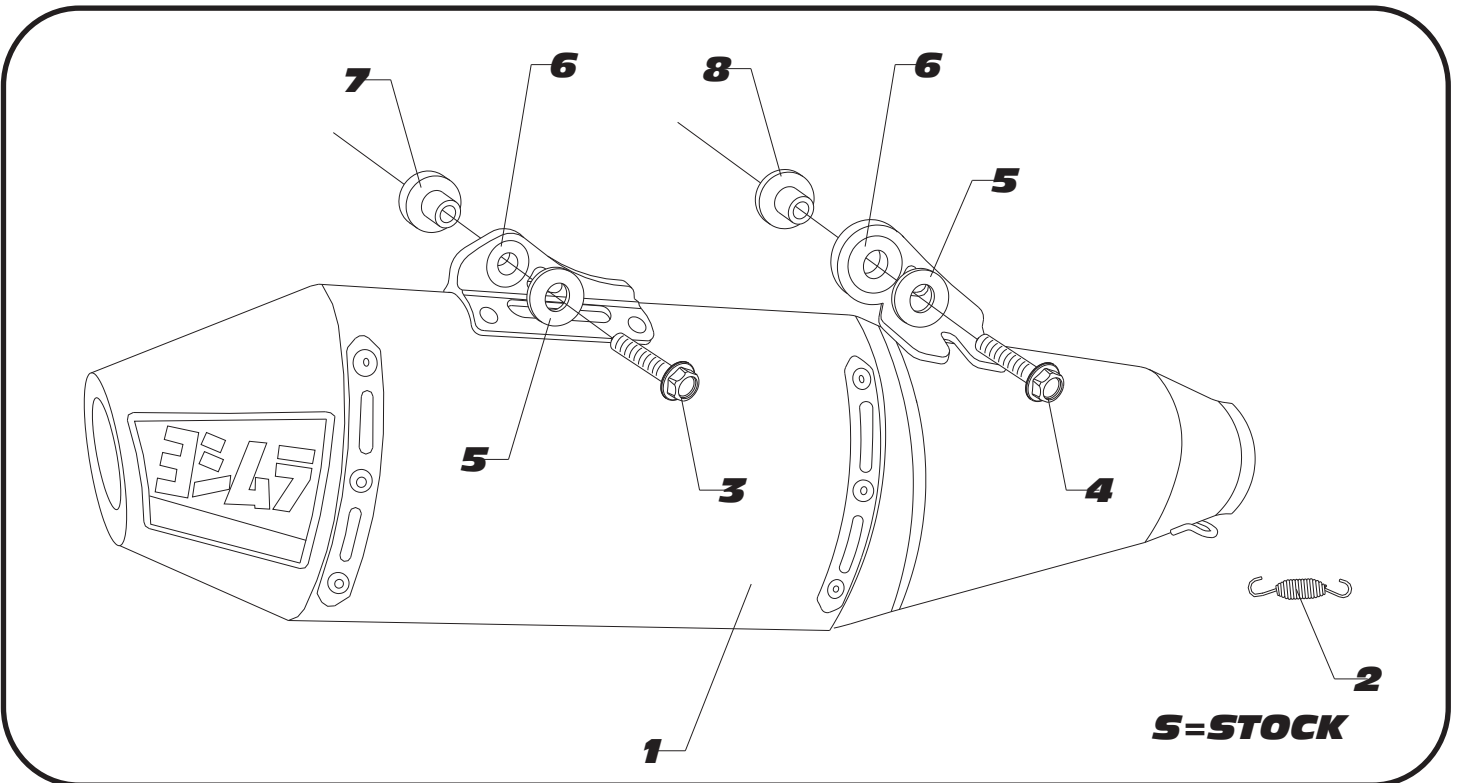

Parts Diagram

NO.	DESCRIPTION	QTY	PART #
1	Yoshimura RS4 Muffler with Aluminum Sleeve	1	263502D321-RMA
2	Medium Exhaust Spring	1	RACE-SPS-1
3	6mm x 45mm Flanged Hex Head Bolt	1	M6X45H
4	6mm x 35mm Flanged Hex Head Bolt	1	M6X35H
5	6mm Flat Washer, XL	2	6MMWASHERXL
6	Rubber Grommet	2	Z1022
7	Aluminum Spacer	1	ALS-022
8	Aluminum Spacer	1	ALS-023
**	450SX-F AMA 94dB Sound Insert (Installed)	1	INS-2M26-K
**	Spark Arrestor Kit (Enduro Series)	1	SA-04-K
**	Offroad Endcap Plug	1	347PLUG
**	Spring Puller Tool	1	ST-200
**	Yoshimura Vinyl Sticker	1	17029
OPTIONAL REPLACEMENT PARTS			
Repack Kit		REPACK-RS4-PK11	
250SX-F AMA 94dB Sound Insert		INS-13-K	
250SX-F 2m-MAX Insert Kit		INS-13-K	
350SX-F AMA 94dB Sound Insert		INS-14-K	
350SX-F 2m-MAX Insert Kit		INS-10-K	
450SX-F 2m-MAX Insert Kit		INS-2M26-K	

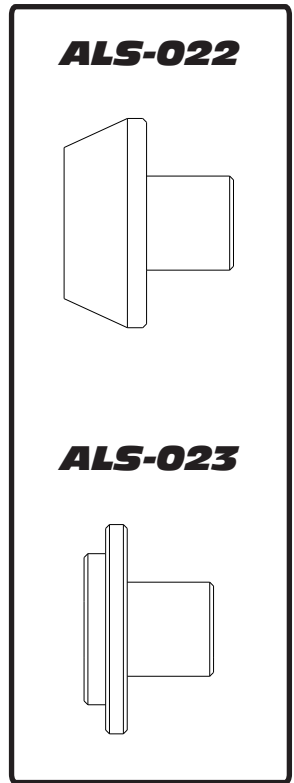



YOSHIMURA

RESEARCH&DEVELOPMENT OF AMERICA, INC.

5420 DANIELS STREET SUITE A, CHINO, CA 91710 · (800)634-9166 · (909)628-4722 · FACSIMILE (909)591-2198

www.yoshimura-rd.com

INS-2M26-K | YOSHIMURA 2M MAX SOUND INSERT KIT

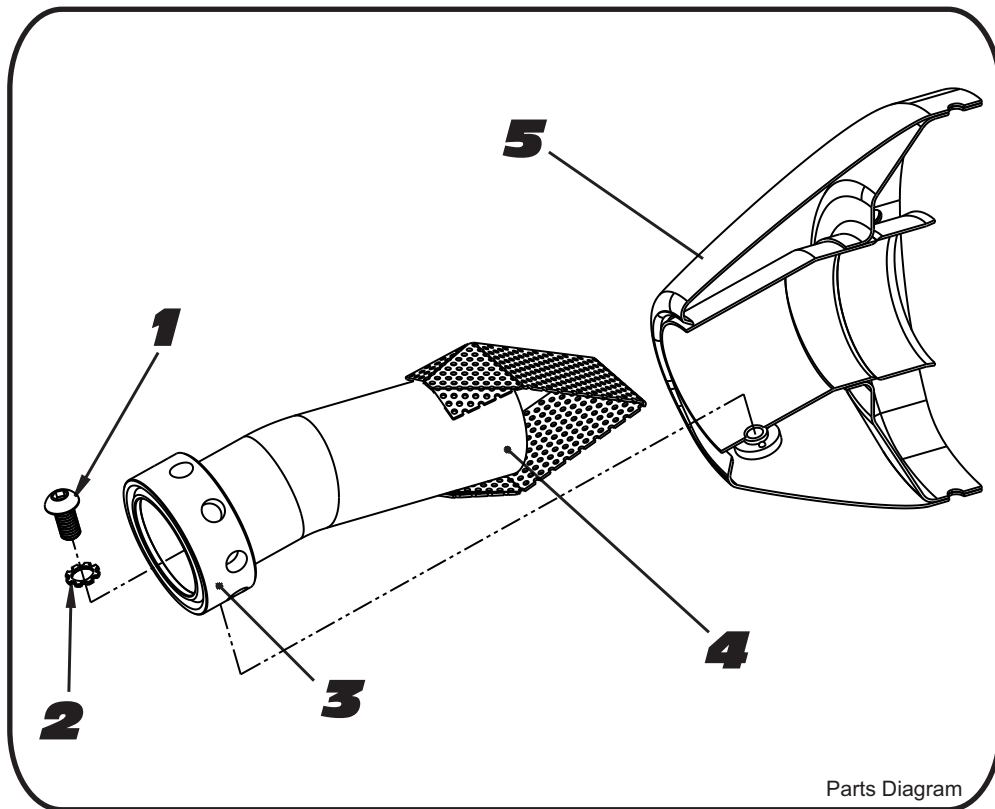

NO.	DESCRIPTION	QTY	PART #
1	6mm X 12mm Button Head Cap Screw	1	M6X12BHS
2	6mm Lock Washer	1	6MMLCKWSHR-TH
3	RS4 Spark Arrestor Ring 1.375"	1	RS4-RING-1375
4	RS4 2M Max Insert	1	INS-SSP-1.38X65
5	Yoshimura Exhaust	**	**

- 1 Using a 4mm Allen key, remove the bolt that secures the aluminum ring and sound insert to the muffler (see Parts Diagram for location).
- 2 Remove the sound insert from the muffler.
- 3 Inspect the sound insert for cracks or damage and replace if necessary.
- 4 Re-install sound insert and aluminum ring. Torque the sound insert securing bolt to 1.0 kg-m (7.3 lb-ft).
NOTE: It is recommended that a low strength "Loc-tite" is used on the sound insert securing bolt.