



YOSHIMURA

RESEARCH&DEVELOPMENT OF AMERICA, INC.

5420 DANIELS STREET STE A, CHINO CA., 91710 · (800) 634-9166 · (909) 628-4722 · FAX (909) 591-2198

www.yoshimura-rd.com

Street Series

Qualified Manufacturer Declared "Replacement Part"

2017

BMW S1000RR

15203MP720 (TI/CF)

Alpha Taper Slip-On

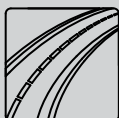

All Street Series systems are:

- Slip-on/Bolt-on applications that do not require tampering with the vehicle's emissions control system.
- CARB/EPA tail-pipe emissions compliant.
- Marked with appropriate EPA noise labels.
- Not tested for EPA new vehicle noise compliance.

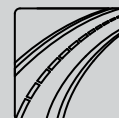

✘ You must know how to remove and replace your stock exhaust in order to install this product otherwise have it installed by a professional mechanic. Keep all stock parts from your existing system as some components may be necessary to install your new Yoshimura exhaust depending on the application. Read through all instructions before beginning installation. Exhaust system can be extremely hot. Let motorcycle cool down before beginning installation. Always wear hand and eye protection and take precautionary measures to avoid injury. ✘

NOTE: IN THE STATE OF CALIFORNIA, IT IS ILLEGAL TO MODIFY THE EMISSION CONTROL SYSTEM, WHICH INCLUDES THE CARBURETORS OF ANY VEHICLE.

Assembly Diagram

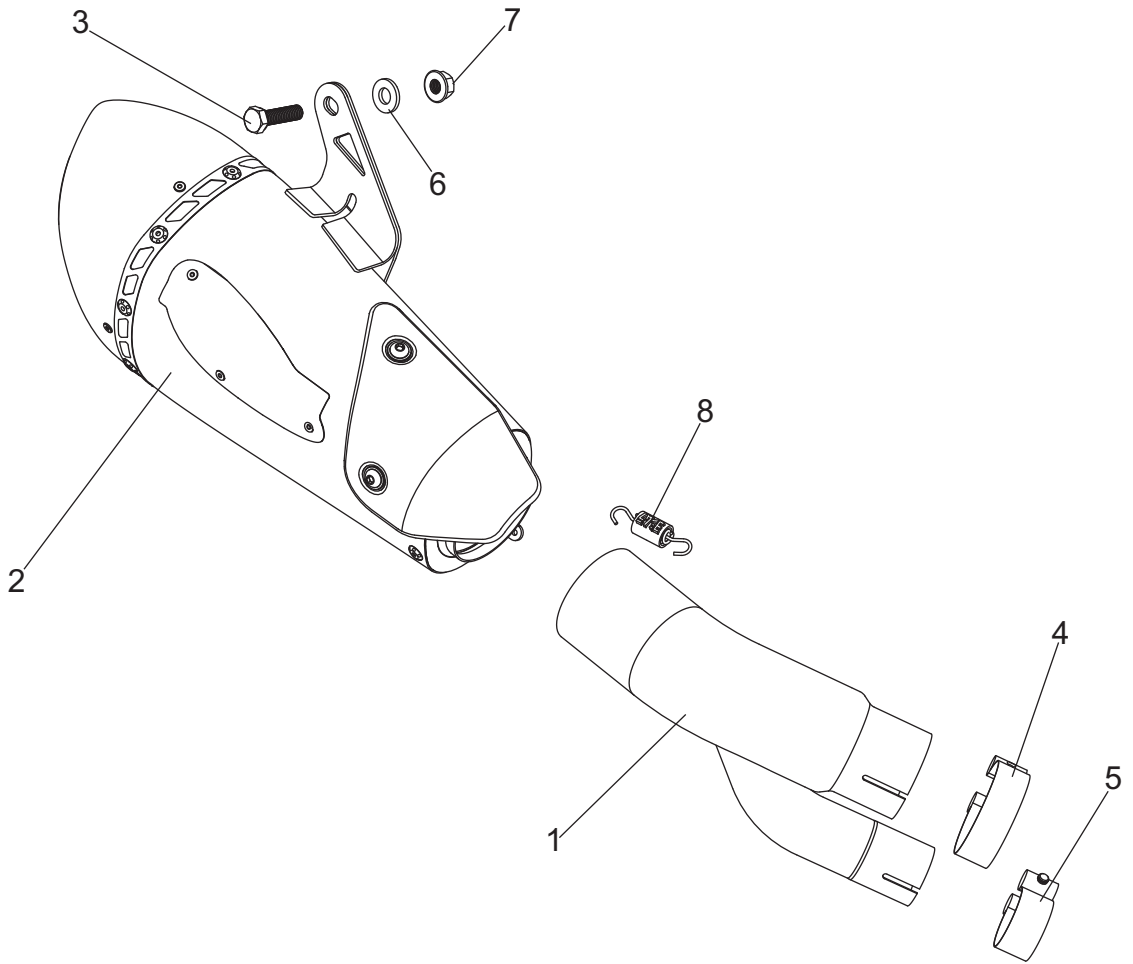

No.	Item	Description	Qty.
1	15203-735	Yoshimura Titanium Tailpipe	1
2	15203MP720-RMA	Yoshimura Titanium Muffler	1
3	M8X30HX	8mm x 30mm Hex Head Bolt	1
4	27-63M	Large Exhaust Clamp	1
5	22053	Small Exhaust Clamp	1
6	8MMWASHER	8mm Flat Washer	1
7	8MMNUT	8mm Flange Nut	1
8	RACE-SPX-1	Small Exhaust Spring	1
**	ST-200	Spring Puller Tool	1
**	17029	Yoshimura Sticker Kit Sheet	1

** Not shown in diagram.

CAUTION: Exhaust system can be extremely hot. Let motorcycle cool down before beginning installation. Always wear hand and eye protection and take precautionary measures to avoid injury.

WARNING: Always properly support vehicle with a stand and/or lift when servicing or performing any work. Unstable vehicles may present dangerous conditions and may cause property damage and/or personal injury.

NOTE: Read through all instructions before beginning installation.

Removal

1. Loosen the two exhaust clamps between the header and muffler connection.
2. Remove the muffler mount nut.
3. Remove the two passenger footpeg bracket bolts and remove passenger footpeg bracket.
4. Carefully remove the stock muffler assembly off of the stock header.

Note: It is recommended to tape or cover swingarm with a rag to prevent scratching during the removal process.

5. The stock muffler mount bolt in the passenger footpeg bracket is too long and will need to be replaced. Remove circlip below footpeg pin and remove footpeg pin. Carefully remove footpeg assembly making sure not to lose the detent ball and remove the stock muffler mount bolt.

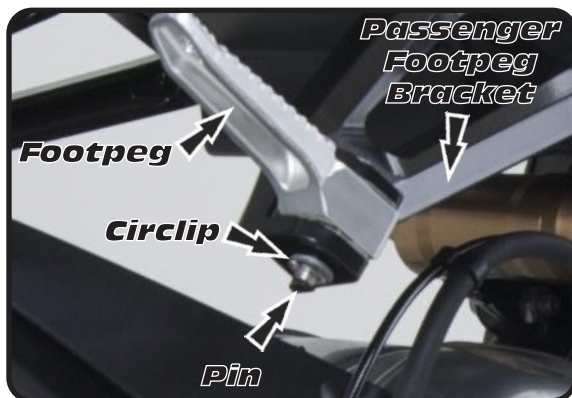

Installation

1. Re-install footpeg bracket using the two stock bolts. Do not torque at this time.
2. Slide (No. 4,5) 27-63M & 22053, large and small exhaust clamps over (No. 1) 15203-735, tailpipe inlet tubes.
3. Install (No. 2) muffler onto tailpipe outlet.
4. Install muffler/tailpipe assembly over the stock header outlets and align muffler bracket to the backside of the passenger footpeg bracket. Install (No. 3) M8X30HX, 8mm bolt into passenger footpeg bracket and through muffler bracket and secure using (No. 6) 8MMWASHER, 8mm flat washer and (No. 7) 8MMNUT, 8mm flange nut. Do not torque at this time.



5. Torque passenger footpeg bracket bolts to factory specification.
6. Torque (No. 7) 8MMNUT, 8mm flange nut to 23 Nm (2.3 kg-m, 17 ft-lb).
7. Torque (No. 4,5) 27-63M & 22053, exhaust clamps to 8.5 Nm (0.86 kg-m, 6 ft-lb).
8. Install (No. 8) RACE-SPX-1, small exhaust spring between tailpipe and muffler using ST-200, spring puller tool supplied in the kit.
9. Re-install passenger footpeg into footpeg bracket using opposite steps of removal. Verify that the circlip is properly seated onto the pin.
10. Before starting vehicle, check for proper clearance between new exhaust system and rear suspension (i.e. tire, swingarm, brakes, rear shock, and etc.) If any problem is found, please carefully follow through the installation steps again. If problem still persists, please call Yoshimura Tech Department at (800) 634-9166 / in CA (909) 628-4722.

11. It is recommended that the muffler and tailpipe be wiped down with rubbing alcohol to remove oil and fingerprints. This will help prevent tarnishing of the finish after the exhaust is heated up.

Note: After starting vehicle, it is normal for new exhaust system and muffler to emit smoke until oil residue burns off.

Works Finish Care & Maintenance

Before starting vehicle, clean pipe thoroughly using a soft cloth and rubbing alcohol to remove any oil and finger prints.

The color of the exhaust will change once the system has gone through a heat cycle of 15 minutes or more. Color will vary depending on lean/rich conditions.

Clean using a soft cloth and soap. Do not use abrasive materials as it will scratch the surface.

Surface reconditioning services are available to remove scratches and undesirable discoloration due to extreme heat. Contact Yoshimura Tech Department at (800) 634-9166 / in CA (909) 628-4722 for more information.